

Appendix A

# Trenchless Construction Techniques Analysis



**Water Corporation**  
**Trenchless Construction Techniques Analysis**  
**Balannup Pressure Main**

September 2013

This page has been left blank intentionally.

# Executive Summary

In order to continue to service the rapidly growing Balannup (Southern) corridor between Armadale Rd and Ranford Rd the Water Corporation needs to construct 4.5km of sewerage pipeline to connect Collared Rd Pump Station (PS) in Harrisdale to Water Works Rd PS in Haynes.

Of the 4.5km of sewerage pipeline needed, 1.5km traverses a 'Bush Forever' area. Alternative paths for the pipeline which avoid the 'Bush Forever' area are not feasible due to the vicinity of major transport routes and severe congestion of existing underground services.

In order to minimise the environmental impact of constructing the pipeline through the 'Bush Forever' area the Water Corporation is seeking to utilise a 'Trenchless' construction technique. This report represents the outcome of an investigation into the most suitable technique.

A wide range of 'Trenchless' techniques have been evaluated. All but one technique have been eliminated due to either a requirement for some excavation within the 'Bush Forever' area or due to the resultant pipeline being unsuitable for operation by the Water Corporation.

Use of 'Ploughing' technology is recommended as the least invasive and most suitable of existing 'Trenchless' techniques. A 'Plough' can install a DN-450 pipe through the 'Bush Forever' area along an existing cleared track without the requirement for any clearing or dewatering. The pipe can be installed at a constant grade and at a suitable depth with no ongoing operational or environmental risks.

# Table of contents

Executive Summary .....	i
1. Introduction .....	1
1.1 Background .....	1
1.2 Scope.....	1
2. Pipeline design considerations .....	2
2.1 General .....	2
2.2 Sedimentation .....	2
2.3 Geotechnical and groundwater .....	2
3. Trenchless technology techniques.....	3
3.1 Pipe jacking and guided boring .....	3
3.2 Horizontal directional drilling (HDD) .....	3
3.3 Ploughing.....	4
4. Conclusions and recommendations.....	6

## Appendices

Appendix A – Route diagram

Appendix B – HDD layouts and profiles

Appendix C – Eco Plough dimensions

Appendix D – Proposed ‘Eco Plough’ alignment

Appendix E – Geotechnical investigation

# 1. Introduction

## 1.1 Background

Water Corporation is planning a Mechanical and Electrical upgrade of the Collared Street Wastewater Sewerage Pump Station (WWPS) and to construct a new pressure main along Keane Road to the Waterworks Road WWPS in Haynes. See Water Corporation's sketch of pipeline route at Appendix A.

GHD has been commissioned to carry out the Engineering and Detailed Design for the project.

The chosen alignment of the proposed pressure main along Keane Road passes through a 'Bush Forever' conservation area. The local government authority, City of Armadale, has a road reserve located across the 'Bush Forever' land. A recent proposal by City of Armadale to construct a sealed road within the road reserve has been deferred by the regulatory authorities.

Alternative alignments along Skeet Road and Armadale or Ranford Road have been ruled out by the Water Corporation because of severe congestion of existing underground services and high volume traffic corridors.

There is understandably strong pressure from community groups and environmental regulators for preservation of the 'Bush Forever' area. As such conventional open trenching will not be acceptable and the Water Corporation has subsequently identified trenchless techniques as the way forward.

This report is intended to provide Water Corporation with an overview of available 'Trenchless' construction techniques and discuss the feasibility, risks and opportunities that each offers.

## 1.2 Scope

This report provides background information as a basis for understanding options, limitations, risks and opportunities associated with trenchless techniques specific to the application of construction of a sewerage pressure main underneath the 'Bush Forever' area at Harrisdale.

The majority of the pressure main is to be DN375 PVC pipe as advised by the Water Corporation, but with HDPE used under the 1.5km 'Bush Forever area'. Trenchless techniques generally require a wall thickness based on the tensile strength required for pulling the pipe into position and this will require an HDPE pipe of 450mm outer diameter.

## 2. Pipeline design considerations

### 2.1 General

The design as requested is for a pipeline on a grade with scour valves and air valves at regular intervals. No air valves or scour valves will be permissible within the 'Bush Forever' area. It is therefore a requirement that the final profile of the pipeline has the following characteristics in order to provide a workable pressure main.

- Continuous descent from an air release point (valve) to a low point followed by
- Continuous ascent to another air valve
- No inverted U configurations where air may become trapped (preventing pumping)

### 2.2 Sedimentation

It is inevitable that some sedimentation in the pipeline will occur. Appropriate flow velocities can minimise sedimentation build up but some means of sediment removal must be considered. Under normal circumstances a scour valve will provide means of sediment removal but a scour valve is not permissible within the 'Bush Forever' area. Therefore two possibilities exist:

- The low point of the section running under the 'Bush Forever' area must occur at one end, just outside the conservation zone
- The section under the 'Bush Forever' area must rely on pigging to remove sediment

Any technique used to construct the pressure main must provide a profile that can be managed for sediment removal.

### 2.3 Geotechnical and groundwater

In summary the geotechnical and groundwater conditions expected are generally iron or silica cemented silty sand or peaty sand with groundwater at a shallow depth. As such geotechnical issues are not expected to provide any impediments to the use of trenchless techniques. A separate geotechnical report has been prepared to accompany the Engineering Summary Report and this provides a more detailed investigation. Some brief information is provided at Appendix E.

## 3. Trenchless technology techniques

Trenchless technology has been in development for pipe installation since the 1970s, arising from the oil and gas industry in the United States. Around the world many contractors offer services employing variations of the technology for the purposes of replacing existing services or installation of new services.

Trenchless techniques to be evaluated as alternatives for the purposes of construction of the DN-450 sewerage pipeline are:

1. Pipe Jacking and Guided Boring
2. Horizontal Directional Drilling
3. Ploughing

Tunnel boring as used for the Channel Tunnel between England and France and extensively across Scandinavia is not considered in this family of pipe laying techniques and is beyond the scope of this report.

### 3.1 Pipe jacking and guided boring

Pipe Jacking uses hydraulic equipment to push lengths of pipe through the ground. Guided Boring uses hydraulics to power a drilling head with spoil taken away by an auger. Alignment is maintained by laser.

Both of these techniques begin with the construction of a shaft that accesses the initial starting elevation (depth) of the pipe to be installed. Equipment to drill or thrust is lowered into the pit and the installation is made in a straight line penetration through the ground. Pit size is dependent on the specific technique and equipment but for this project a minimum pit plan size of 5m x 5m can be expected. Each pit would require clearing, dewatering and ASS management. Excavation would very probably extend below the water table making it more difficult and expensive.

The limit to these construction techniques varies with geotechnical conditions and specific technique involved but in general no installation has been made extending more than approximately 150 meters from a pit. Where greater distances need to be installed then a second pit is required to receive the incoming pipe and the process is repeated to extend again in any direction from this second pit.

Therefore, this method would require a significant level of construction activity within the 'Bush Forever' area with approximately ten 5m x 5m pits required.

### 3.2 Horizontal directional drilling (HDD)

HDD is a trenchless method of installing underground conduits, pipes and cables from the surface. In this group of techniques the drill process begins at ground level from a prepared launch site. The drill is directed into the ground at a relatively steep angle in order to get the drilling head underground and away from the surface as quickly as possible.

The drilling is performed with the assistance of drilling fluids or "mud". Drilling mud primarily consists of Bentonite and water although in some cases synthetic muds and plasticizers are also used. The mud is pumped under high pressure through the drill string; it powers the drill motor and mixes with the drill cuttings (drill spoil) and the mixture then returns to the drill site. The mud is then processed to remove the cuttings and reused. Another function of the mud is to support the hole from collapse in weak ground.



The installation process begins with construction of entry and exit pits. Estimates of the required area needed for the entry pit construction area for the Balannup project is estimated at approximately 30m x 90m. These pits collect the drilling mud and allow it to be reused. See diagram at Appendix B for full depiction of the drilling pits and construction profile.

Within HDD techniques there are three alternatives, Single Stage HDD, Multi Stage HDD and Intersect Drilling.

### 3.2.1 Single Stage HDD

The maximum length of a single construction stage varies with ground conditions and with available equipment capacity. Generally however, the maximum length of a single stage is in the range of 600m to 1000m.

Additional risks with this methodology include the drilling fluid (bentonite) bursting through to the surface, particularly in the early stages of the bore. Also, HDD has been known to result in low accuracy in both horizontal and vertical planes of +/- 1 to 2m.

Single Stage HDD can be ruled out as a feasible option due to the reasons stated above.

### 3.2.2 Multi Stage HDD

A pipeline may be installed in multiple stages in a 'Daisy Chain' profile. In the case of this project, the length of the installation required means that one or two intermediate construction pits are to be located within the 'Bush Forever' area. In addition to the limitations highlighted within Single Stage HDD this would result in significant impact on the 'Bush Forever' area and can be ruled out also.

### 3.2.3 Intersect Drilling

Intersect drilling almost doubles the potential installation length compared to a single drive. HDD techniques with single stages in the order of 1km are possible depending on geotechnical conditions. The reach may be effectively doubled by drilling from two starting points to meet in the middle. To date the longest pipeline successfully installed in Australia using this method is approximately 2.2 km.

Any option involving intersect drilling would have to begin some distance from the 'Bush Forever' area. This increases the length and therefore the cost of this option. Additionally, there are also implications for the accuracy of the construction meaning risk of impact to the 'Bush Forever' area and costs to the Water Corporation should the method prove unsuccessful during construction.

The depth of installation also presents a significant risk to the Water Corporation and the environment. For any application of HDD there is a requirement to drill steeply through the surface material and maintain that steep profile up or down to a low point in order to avoid trapping air and making pumping impossible. This low point has been estimated conservatively at approximately 25m below natural surface level. A depiction is provided in Appendix B.

In the unlikely event of a requirement to access this pipeline for maintenance or repair it would involve significant excavation in the 'Bush Forever' area and present enormous costs and risk to the Water Corporation.

## 3.3 Ploughing

Ploughing is a construction technique whereby a machine installs a narrow trench in the ground where neither soil removal nor dewatering is required. Either simultaneously or later a pipe is inserted at a controlled depth. Ploughing is considered in the industry as a trenchless technique.

There are several contractors offering this service in Australia. Most offer some variation of the basic process. To date GHD has been in contact with Underground Services Australia (USA) who conducts operations in several states including WA. Their variant of the process, the 'Eco-Plough' is described below.

An 'Eco Plough' drags a vertical plough through the ground creating a narrow trench for the pipe to be inserted within (see Appendix C for a diagram). The 'Eco Plough' then returns to the start of the pipe route where the pipe is lifted over the 'Eco Plough' and installed in equipment mounted behind it. The 'Eco Plough' then drives over the previously created trench and as it does so the pipe is ploughed into the 'trench'. The plough vibrates at high frequency as it inserts the pipe to encourage smaller particulate matter to accumulate around the pipe to form bedding material. All the preceding work is completed within the width of the 'Eco Ploughs' tracks which is less than 4m.

The proposal is to utilise the existing track through which the 'Eco Plough' could install the pipeline without any clearing or dewatering. See proposed pipe route in Appendix D. In some places the track is marginally narrower than the 'Eco Plough'. It is proposed to minimise potential impact by pruning back any affected vegetation prior to the plough going through.

The maximum size of pipe that can be inserted is currently 415 mm in outer diameter but, USA have indicated that modification of the equipment to accommodate 450 mm can be performed in order to meet the requirements of the this project without the need for any modification of the 'Eco Plough' machine overall dimensions.

A concern with the use of the Ploughing technique is its ability to install a pipe at a constant grade appropriate for a sewer main. The plough is able to vary the depth of cover over the pipe as it travels. The maximum depth of insertion is approximately 1.5m. This range is not sufficient to provide a grade of 1:500 of the 1.5 km route, however there is a natural ground level difference over the 1.5 km length of the alignment of approximately 2.5m which together with the adjustable cover gives a suitable grade on the pipe of 1:490 (approximate).

Another issue with the ploughing technique is material compaction around the pipe in order to provide the support it needs in service now and in the future. Over specification of the pipe thickness will be sufficient to provide adequate strength in service. This will be specifically addressed at detailed design stage.

The pipe will be installed in the existing cleared track resulting in the alignment not being straight or following any cadastral boundary. This is not standard for the Water Corporation as it places assets at risk of damage by other work amongst other issues.

In order to mitigate this risk it is proposed that a trace wire is installed to facilitate accurate location in future. There are a number of other factors which negate this issue including:

- There are no air or scour valves within the 'Bush Forever' area meaning that the pipeline does not need to be accessed during normal operation.
- The 'Bush Forever' area provides significant protection to the pipeline given the extreme level of difficulty to gain approval to construct in the area.
- In the future should City of Armadale gain approvals and construct Keane Road the Water Corporation could relay the pipeline (with a duplication if needed) on a consistent alignment within the road reserve.

## 4. Conclusions and recommendations

It is GHD's recommendation that ploughing is taken forward as the preferred option for installation of the pressure main through the Balannup 'Bush Forever' area for the following reason:

- It can be installed without any clearing, open trenching or dewatering.
- It can be installed at a suitable grade over the 1.5km 'Bush Forever' Site with no scour or air valve pits in the 'Bush Forever' site.
- It is cost effective.

# Appendices

# Appendix A – Route diagram

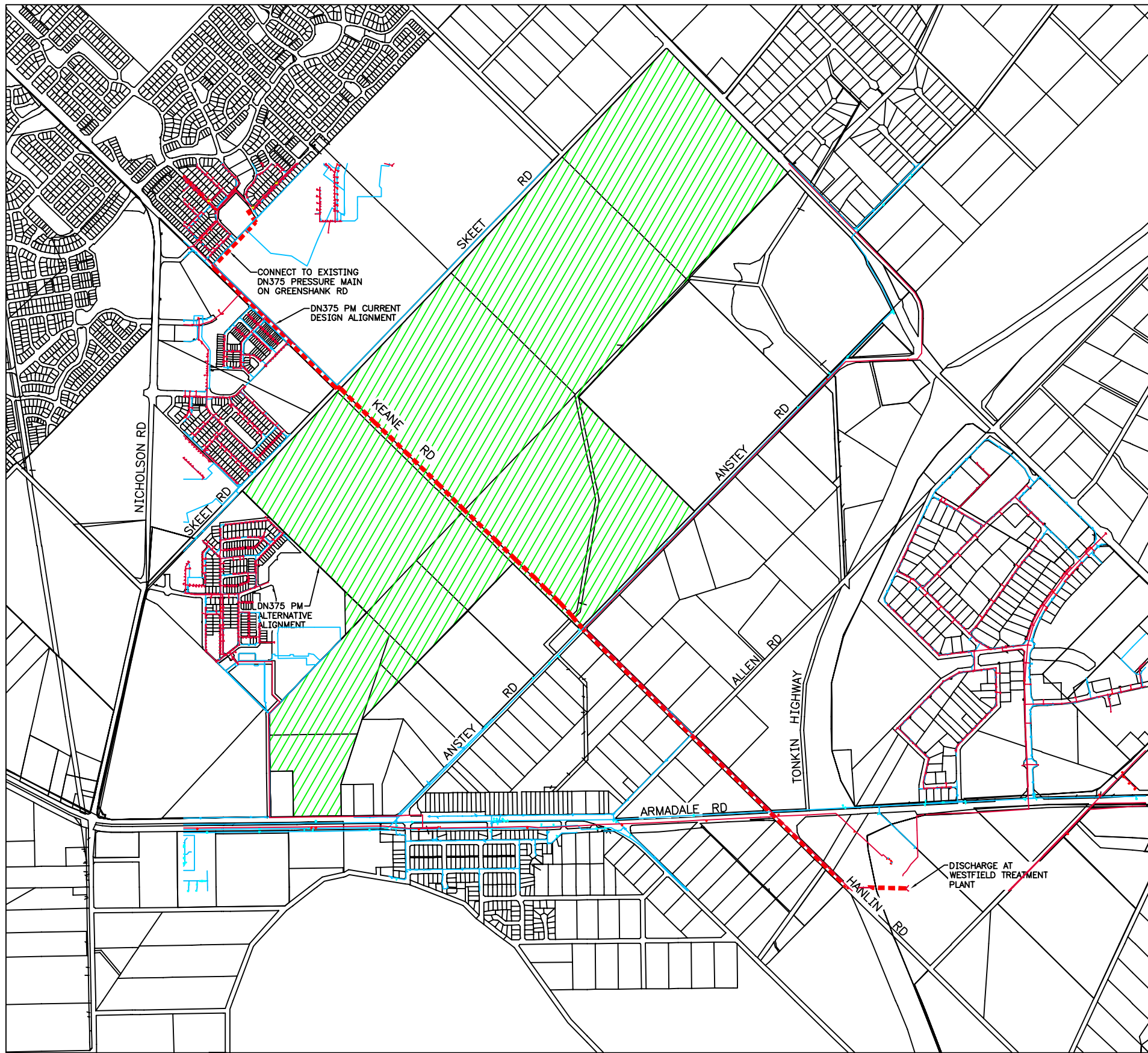

- LEGEND**
- - - - - DN375 PM ALIGNMENT OPTION 1
  - BUSH FOREVER

**PRELIMINARY ONLY**  
NOT TO BE USED FOR CONSTRUCTION

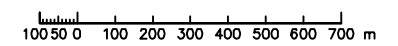

ISSUE	DATE	GRID	REVISION	DRN	REC	APPD

DESIGN SURVEY NONE	VERTICAL DATUM NONE	DES CALC DES CHD	NORTH POINT 
ASCON SURVEY NONE	COORDINATE SYS NONE	DES REF DRN	
		Q.C. CHD	

**INFRASTRUCTURE DESIGN BRANCH**

RECOMMENDED  
CONSULTANT PROJECT MANAGER

APPROVED  
CONSULTANT PROJECT DIRECTOR



METROPOLITAN WASTEWATER BALLANUP PUMPING STATION NO. 175-01 DN375 PRESSURE MAIN ROUTE ALIGNMENT		ORIGINAL SHEET SIZE <b>A1</b>
FILE PROJECT C-S01249	PLAN <b>SKETCH 1</b>	CAD ISSUE B MF

# Appendix B – HDD layouts and profiles

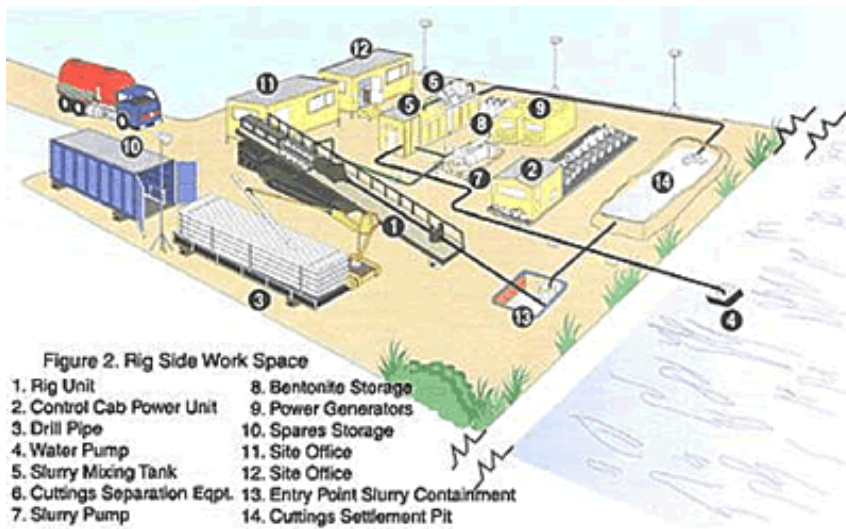

Drawing reproduced with kind permission of HDD Solutions

- Figure 2. Rig Side Work Space**
- |                              |                                    |
|------------------------------|------------------------------------|
| 1. Rig Unit                  | 8. Bentonite Storage               |
| 2. Control Cab Power Unit    | 9. Power Generators                |
| 3. Drill Pipe                | 10. Spares Storage                 |
| 4. Water Pump                | 11. Site Office                    |
| 5. Slurry Mixing Tank        | 12. Site Office                    |
| 6. Cuttings Separation Eqpt. | 13. Entry Point Slurry Containment |
| 7. Slurry Pump               | 14. Cuttings Settlement Pit        |

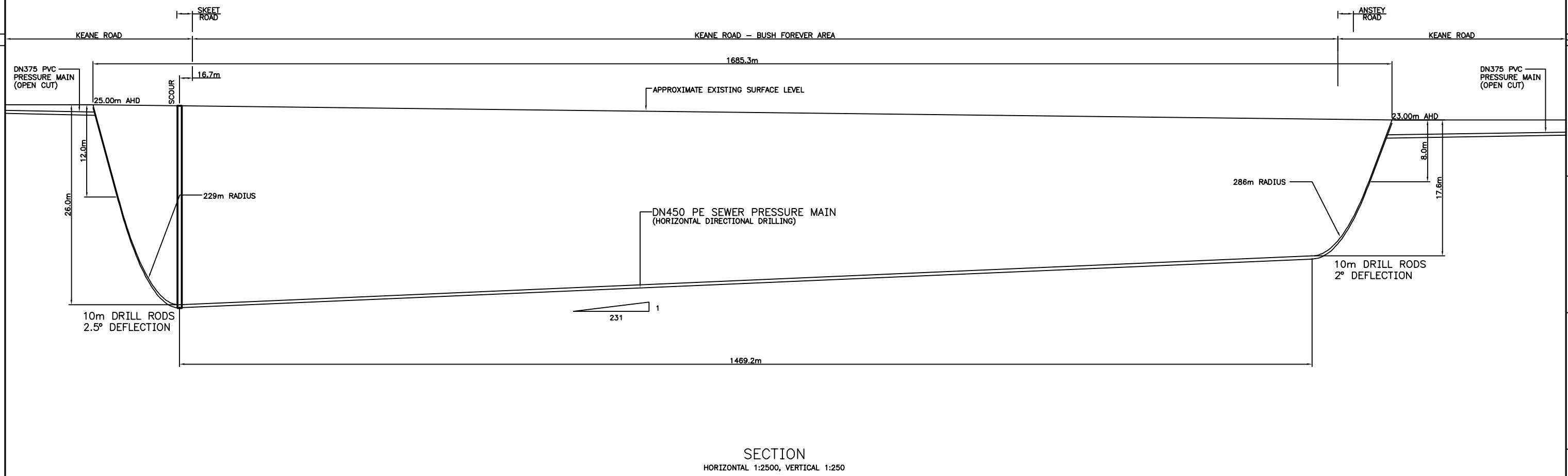
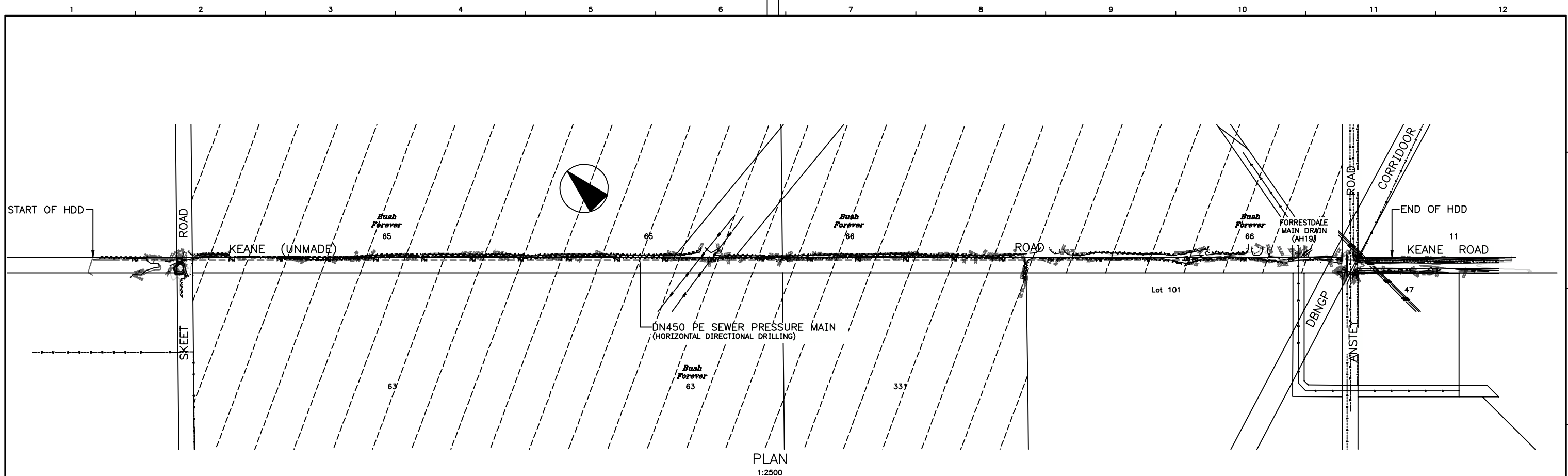

**ENGINEERING DESIGN - NOT FOR CONSTRUCTION**

DATE: 28-May-2013

1	05/13	ISSUED FOR INFORMATION	KB	GD	PGS	
ISSUE	DATE	GRID	REVISION	DRN	REC	APPD

DESIGN SURVEY GHD 2661551 V01	VERTICAL DATUM AHD	DES CALC N.MAKIN DES CHD	NORTH POINT
ASCON SURVEY NONE	COORDINATE SYS MGA94-50	DES REF GHD 61-29471	DRN K.BOSMAN Q.C. CHD

GHD House, 239 Adelaide Terrace, Perth WA 6004 Australia  
 T 61 8 6222 8222 F 61 8 6222 8555  
 E permail@ghd.com.au W www.ghd.com.au

RECOMMENDED
CONSULTANT JOB MANAGER
APPROVED
CONSULTANT PROJECT DIRECTOR



METROPOLITAN WASTEWATER WAPC 127155 BALANNUP PUMPING STATION NO.175-01 - COLLARED ST & PM ENGINEERING DESIGN - DN375 PRESSURE MAIN PLAN AND SECTION - HDD PROFILE OPTION 1			
FILE PROJECT C-S01249	PLAN HDD OPTION 1	CAD 1	ISSUE 1

ORIGINAL SHEET SIZE <b>A1</b>
----------------------------------



## Appendix C – Eco Plough dimensions

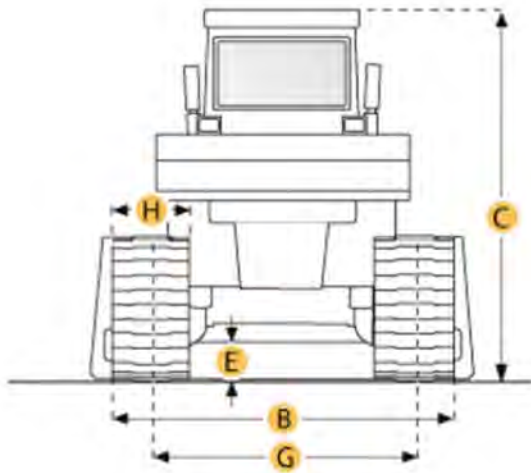

### Selected Dimensions

#### Dimensions

A. LENGTH W/ BLADE	34.9 ft in	10637.5 mm
B. WIDTH OVER TRACKS	11.8 ft in	3606 mm
C. HEIGHT TO TOP OF CAB	13.4 ft in	4078 mm
D. LENGTH OF TRACK ON GROUND	12.7 ft in	3855 mm
E. GROUND CLEARANCE	2.2 ft in	674.5 mm
F. LENGTH W/O BLADE	19.8 ft in	6027 mm

#### Undercarriage

G. TRACK GAUGE	9.5 ft in	2896 mm
H. STANDARD SHOE SIZE	28 in	710 mm



Screenshot from USA Website

# Appendix D – Proposed ‘Eco Plough’ alignment

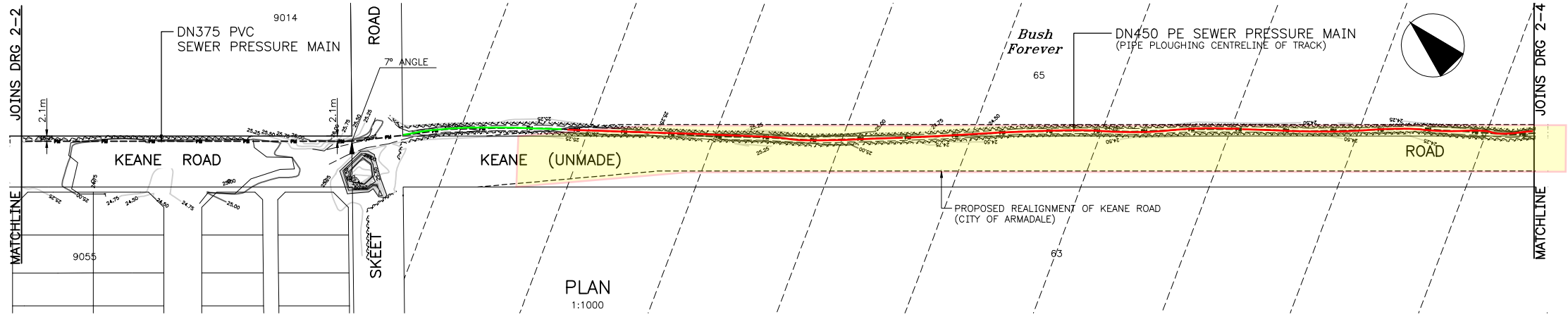

PLAN  
1:1000



NOTE:  
THE LOCATION OF OTHER UTILITIES HAS NOT NECESSARILY BEEN ESTABLISHED BY SURVEY, BUT IS BASED ON DIGITAL SERVICE DATA PROVIDED BY THE ASSET OWNERS AND IS INDICATIVE ONLY. SERVICES MUST BE LOCATED AND VERIFIED ON SITE. FOR MORE INFORMATION CONTACT DIAL BEFORE YOU DIG ON 1100 OR WWW.1100.COM.AU

LEGEND

PROPOSED SEWER PRESSURE MAIN	— PM —
EXISTING WATER MAINS	— W — W — W — W —
EXISTING TELECOMMUNICATION CABLES	— T — T — T — T —
EXISTING OPTIC FIBRE	— OF — OF — OF — OF —
EXISTING UNDERGROUND POWER	— UGP —
EXISTING OVERHEAD POWER	— OP —
EXISTING GAS MAINS	— G — G — G — G —
EXISTING SEWER MAINS	— S — S — S — S —
EXISTING SEWER PRESSURE MAINS	— PM —
EXISTING DRAINAGE	— D — D — D — D —
EXISTING FENCE	— / — / — / — / —
EXISTING TREE	⊙

FOR GENERAL NOTES REFER DRG 85-1-2

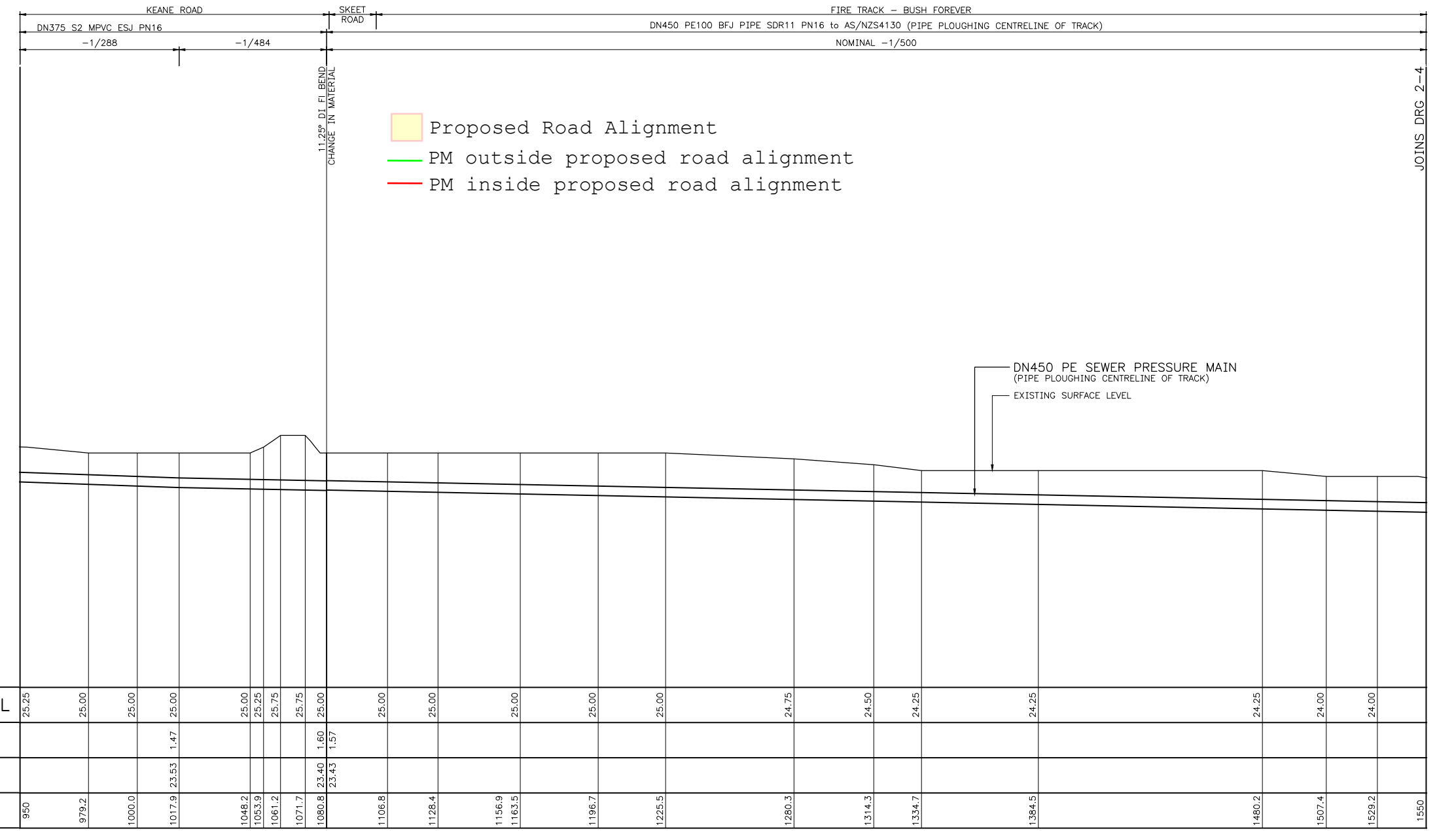

**ENGINEERING DESIGN - NOT FOR CONSTRUCTION** LONGITUDINAL SECTION

DATE: 27-Aug-2013

1	05/13	ISSUED FOR INFORMATION	KB	GD	PCS	DESIGN SURVEY GHD 2661551 V01	VERTICAL DATUM AHD COORDINATE SYS MGA94-50	DES CALC J.POTTS DES CHD	NORTH POINT	RECOMMENDED		METROPOLITAN WASTEWATER WAPC 127155 BALANNUP PUMPING STATION NO.175-01 - COLLARED ST & PM ENGINEERING DESIGN - DN375 PRESSURE MAIN PLAN AND LONGITUDINAL SECTION - SHEET 3 OF 8	ORIGINAL SHEET SIZE <b>A1</b>			
568	ISSUE	DATE	GRID	REVISION	DRN	REC	APPD	ASCON SURVEY NONE	DES REF GHD 61-29471	DRN K.BOSMAN O.C. CHD		CONSULTANT JOB MANAGER	FILE PROJECT C-S01249	PLAN <b>HW91-85-2-3</b>	CAD 1	ISSUE 1

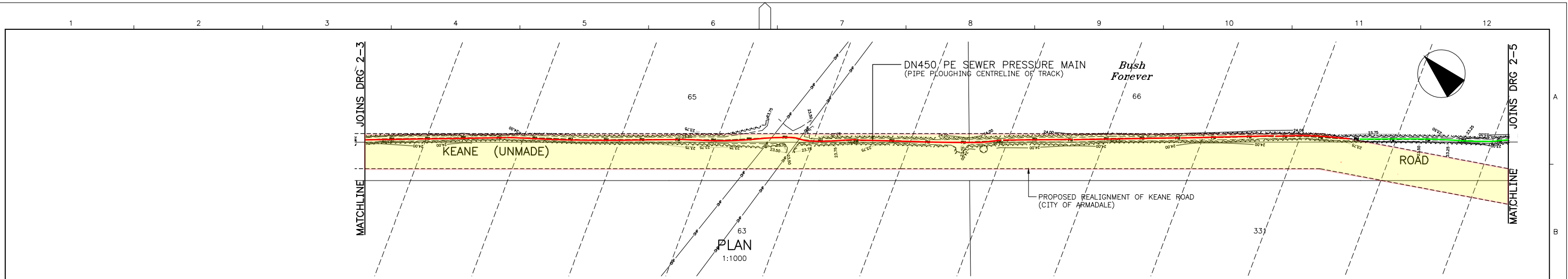

NOTE:  
THE LOCATION OF OTHER UTILITIES HAS NOT NECESSARILY BEEN ESTABLISHED BY SURVEY, BUT IS BASED ON DIGITAL SERVICE DATA PROVIDED BY THE ASSET OWNERS AND IS INDICATIVE ONLY. SERVICES MUST BE LOCATED AND VERIFIED ON SITE. FOR MORE INFORMATION CONTACT DIAL BEFORE YOU DIG ON 1100 OR WWW.1100.COM.AU

LEGEND

- PROPOSED SEWER PRESSURE MAIN
- EXISTING WATER MAINS
- EXISTING TELECOMMUNICATION CABLES
- EXISTING OPTIC FIBRE
- EXISTING UNDERGROUND POWER
- EXISTING OVERHEAD POWER
- EXISTING GAS MAINS
- EXISTING SEWER MAINS
- EXISTING SEWER PRESSURE MAINS
- EXISTING DRAINAGE
- EXISTING FENCE
- EXISTING TREE

FOR GENERAL NOTES REFER DRG 85-1-2

FIRE TRACK - BUSH FOREVER  
DN450 PE100 BFJ PIPE SDR11 PN16 to AS/NZS4130 (PIPE PLOUGHING CENTRELINE OF TRACK)  
NOMINAL -1/500

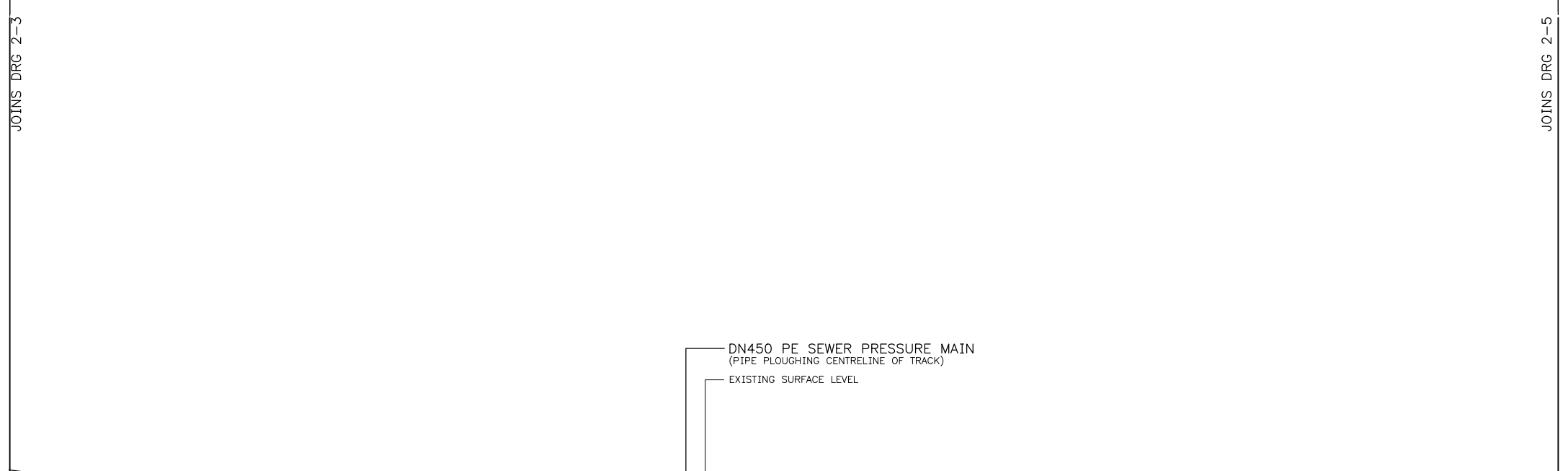

DATUM 15.00m ABOVE AHD																		
NATURAL SURFACE LEVEL		23.75	23.75	23.75	23.50	23.50	23.50	23.50	23.75	23.75	23.75	23.75	23.75	23.75	23.50	23.25	23.00	22.75
DEPTH TO INVERT																		
INVERT LEVEL																		
HORIZONTAL DISTANCE		1350	1565.8	1572.4	1631.8	1719.7	1746.0	1804.3	1836.9	1870.1	1916.3	1929.1	1947.1	2024.8	2076.6	2107.9	2124.0	2150

**ENGINEERING DESIGN - NOT FOR CONSTRUCTION**

LONGITUDINAL SECTION

DATE: 27-Aug-2013

HORIZONTAL 1:1000, VERTICAL 1:100



1	05/13	ISSUED FOR INFORMATION	KB	GD	PCS	DESIGN SURVEY GHD 2661551 V01	VERTICAL DATUM AHD COORDINATE SYS MGA94-50	DES CALC J.POTTS DES CHD	NORTH POINT		RECOMMENDED		METROPOLITAN WASTEWATER WAPC 127155 BALANNUP PUMPING STATION NO.175-01 - COLLARED ST & PM ENGINEERING DESIGN - DN375 PRESSURE MAIN PLAN AND LONGITUDINAL SECTION - SHEET 4 OF 8	ORIGINAL SHEET SIZE <b>A1</b>				
ISSUE	DATE	GRID	REVISION	DRN	REC	APPD	ASCON SURVEY NONE	DES REF GHD 61-29471	DRN K.BOSMAN O.C. CHD	GHD House, 239 Adelaide Terrace, Perth WA 6004 Australia T 61 8 6222 8222 F 61 8 6222 8555 E permail@ghd.com.au W www.ghd.com.au	CONSULTANT JOB MANAGER	APPROVED	CONSULTANT PROJECT DIRECTOR	FILE PROJECT C-S01249	PLAN <b>HW91-85-2-4</b>	CAD 1	ISSUE 1	MF

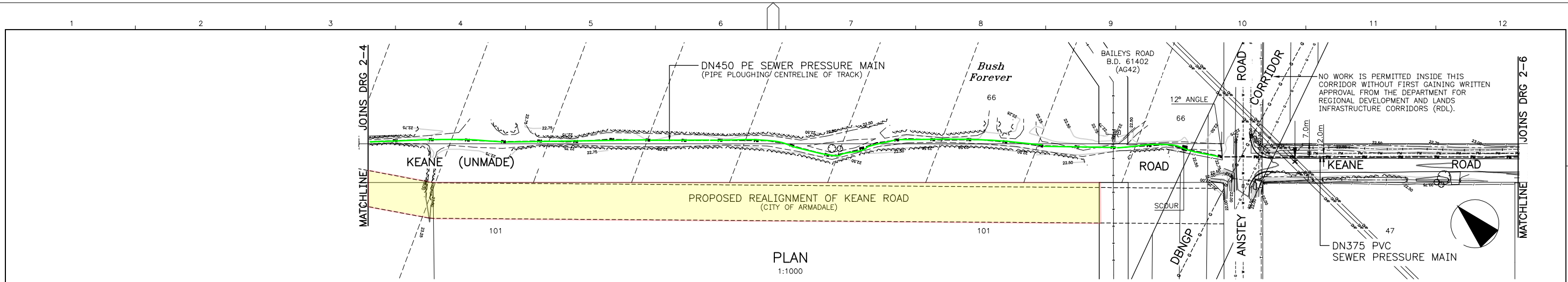

PLAN  
1:1000



NOTE:  
THE LOCATION OF OTHER UTILITIES HAS NOT NECESSARILY BEEN ESTABLISHED BY SURVEY, BUT IS BASED ON DIGITAL SERVICE DATA PROVIDED BY THE ASSET OWNERS AND IS INDICATIVE ONLY. SERVICES MUST BE LOCATED AND VERIFIED ON SITE. FOR MORE INFORMATION CONTACT DIAL BEFORE YOU DIG ON 1100 OR WWW.1100.COM.AU

LEGEND

- PROPOSED SEWER PRESSURE MAIN
- EXISTING WATER MAINS
- EXISTING TELECOMMUNICATION CABLES
- EXISTING OPTIC FIBRE
- EXISTING UNDERGROUND POWER
- EXISTING OVERHEAD POWER
- EXISTING GAS MAINS
- EXISTING SEWER MAINS
- EXISTING SEWER PRESSURE MAINS
- EXISTING DRAINAGE
- EXISTING FENCE
- EXISTING TREE

FOR GENERAL NOTES REFER DRG 85-1-2

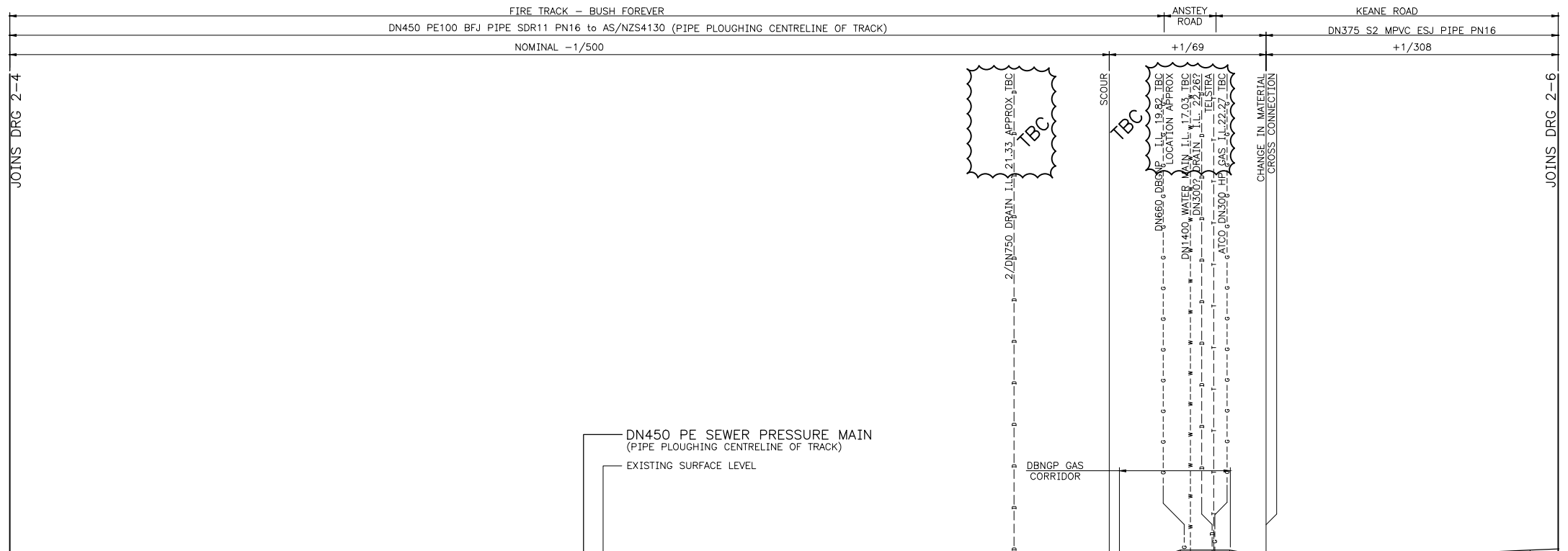

DATUM 15.00m ABOVE AHD		2150	2183.0	2251.9	2295.7	2424.3	2531.6	2542.1	2566.5	2576.0	2583.6	2596.5	2603.6	2622.7	2636.8	2683.8	2739.1	2750
NATURAL SURFACE LEVEL		22.75	22.75	22.50	22.50	22.25	22.25	22.25	22.25	22.50	22.75	23.00	23.00	22.75	22.75	23.00		
DEPTH TO INVERT									1.82					1.45	1.46			
INVERT LEVEL									20.42					21.30	21.29			
HORIZONTAL DISTANCE		2150	2183.0	2251.9	2295.7	2424.3	2531.6	2542.1	2566.5	2576.0	2583.6	2596.5	2603.6	2622.7	2636.8	2683.8	2739.1	2750

**ENGINEERING DESIGN - NOT FOR CONSTRUCTION** LONGITUDINAL SECTION

DATE: 27-Aug-2013

1	05/13	ISSUED FOR INFORMATION	KB	GD	PGS	DESIGN SURVEY GHD 2661551 V01	VERTICAL DATUM AHD COORDINATE SYS MGA94-50	DES CALC K.BOSMAN DES CHD	NORTH POINT	RECOMMENDED		METROPOLITAN WASTEWATER WAPC 127155 BALANNUP PUMPING STATION NO.175-01 - COLLARED ST & PM ENGINEERING DESIGN - DN375 PRESSURE MAIN PLAN AND LONGITUDINAL SECTION - SHEET 5 OF 8	ORIGINAL SHEET SIZE	
ISSUE	DATE	GRID	REVISION	DRN	REC	APPD	ASCON SURVEY NONE	DES REF GHD 61-29471	DRN K.BOSMAN O.C. CHD	CONSULTANT JOB MANAGER		FILE	CAD	ISSUE
										APPROVED		PLAN		
										CONSULTANT PROJECT DIRECTOR	PROJECT C-S01249	HW91-85-2-5	1	MF

566  
810

# Appendix E – Geotechnical investigation

## Published data on ground conditions

Ground conditions are shown on published 1:50,000 scale maps as predominantly “thin Bassendean Sand overlying Guildford Formation”. Bassendean Sand is aeolian quartz sand, with a typical relative density of medium dense. A thin covering of Bassendean Sand, in the local context, implies a thickness between approximately 5 m and less than 1 m.

The Guildford Formation is an alluvial deposit, comprising a mixture of a wide variety of soil types. Local experience suggests that it is likely to principally comprise Clayey Sand or Silty Sand. Iron- or silica- cemented soils are known in the area, particularly where the Guildford Formation is overlain by Bassendean Sands with shallow groundwater. Often an iron-cemented Silty Sand (colloquially called “Coffee Rock”) forms at the interface between the two units, where seasonal fluctuation of the groundwater table results in precipitation of dissolved iron in the groundwater.

Discrete zones of “peaty sand” are mapped for the ‘Bush Forever’ locality. Along the proposed pressure main route, two such locations are shown. One is approximately central to the ‘Bush Forever’ component of the alignment, the other near the southern boundary. Local experience suggests peaty sand is likely to comprise Silty Sand with significant diatomite content. These can be acid sulphate soil risks.

A number of exploratory boreholes have been drilled in the area by various government agencies. A graphic lithology log of these boreholes, shown with the published ground conditions map, indicates these comprise sand only to between 25 and 30 m depth overlying the Osborne Formation. The borehole locations appear to be confined to localities where Peaty Sand is mapped and may not be representative of the broader ground conditions.

The Osborne Formation in this area comprises the Kardinya Shale member. Published information suggests the interface between the Osborne Formation and superficial units to be approximately -10 m AHD. The Kardinya Shale consists of moderately to tightly consolidated interbedded siltstones and shales. These are often puggy, glauconitic and contain thin interbeds of fine grained sandstone. It is also a confining bed for the underlying Leederville aquifer. Kardinya Shale is likely to persist to approximately -40 m AHD.

## Groundwater Conditions

Published data (Davidson, 1995) shows that groundwater is shallow, with actual depth fluctuating seasonally. Groundwater is likely to be brackish and high in dissolved iron.

To the west of ‘Bush Forever’ land is the Jandakot mound, which is one of the more important groundwater supply and recharge areas for the Perth metro area. The ‘Bush Forever’ site occupies a col between the Jandakot mound (~25 m AHD) and the Armadale area recharge (water table also ~25 m AHD). Therefore superficial groundwater should be expected at slightly less than 25 m AHD.

The Leederville aquifer is a confined aquifer that, in the vicinity of the site, is contained by the Kardinya Shale member of the Osborne Formation. Interaction with the Leederville aquifer should be avoided or minimised, as the risk of undesirable environmental impacts is relatively high.

GHD

239 Adelaide Tce  
Perth WA 6000

T: (08) 6222 8222 F: (08) 6222 8555 E: permail@ghd.com

© GHD 2013

This document is and shall remain the property of GHD. The document may only be used for the purpose for which it was commissioned and in accordance with the Terms of Engagement for the commission. Unauthorised use of this document in any form whatsoever is prohibited.

G:\61\29471\WP\HDD Report\20131004\Trenchless option report Rev 4.docx

Document Status

Rev No.	Author	Reviewer		Approved for Issue		
		Name	Signature	Name	Signature	Date
0	G Dunlop	P Spencer	<i>Peter Spencer</i>	P Spencer	<i>Peter Spencer</i>	4/7/2013
1	G Dunlop	P Spencer	<i>Peter Spencer</i>	P Spencer	<i>Peter Spencer</i>	11/9/2013
2	G Dunlop	P Spencer	<i>Peter Spencer</i>	P Spencer	<i>Peter Spencer</i>	17/9/2013
3	G Dunlop	P Spencer	<i>Peter Spencer</i>	P Spencer	<i>Peter Spencer</i>	24/9/2013
4	G Dunlop	J Foley	<i>J Foley</i>	J Foley	<i>J Foley</i>	4/10/2013

[www.ghd.com](http://www.ghd.com)





This page has been left blank intentionally.

This page has been left blank intentionally.

## Appendix B

# EcoPlough

This page has been left blank intentionally.

1

2

3

4

5

6

A

B

C

D

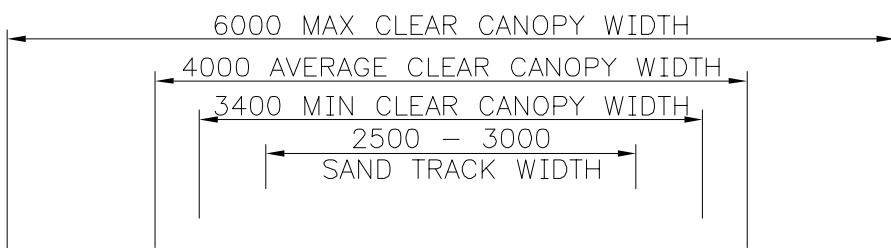

CURRENT SURVEY INFORMATION

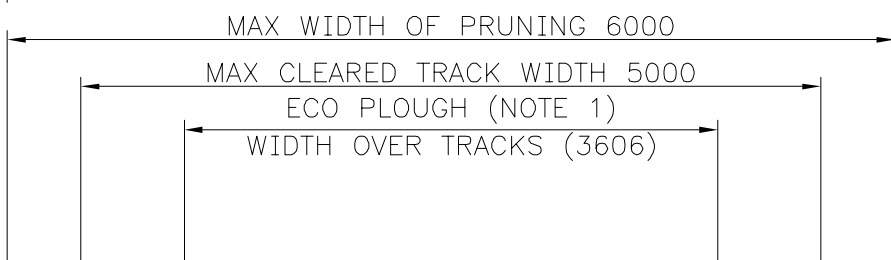

CONSTRUCTION REQUIREMENTS

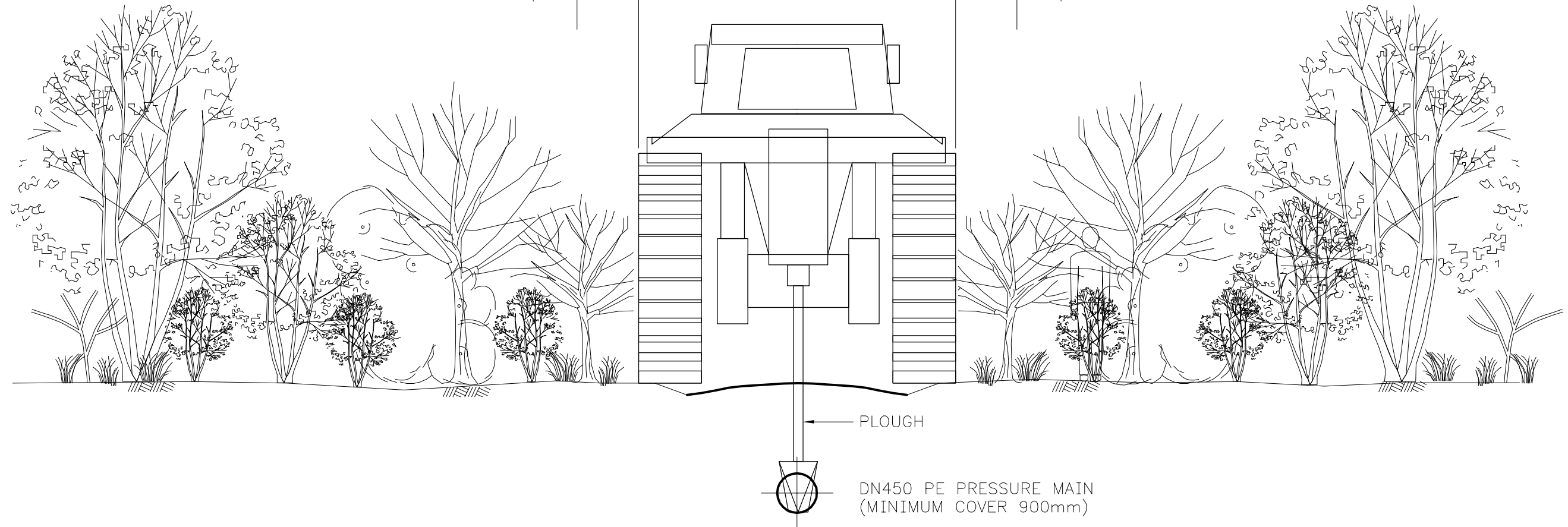

PLOUGH

DN450 PE PRESSURE MAIN (MINIMUM COVER 900mm)

NOTE

1. DIMENSIONS BASED ON CATERPILLAR D11

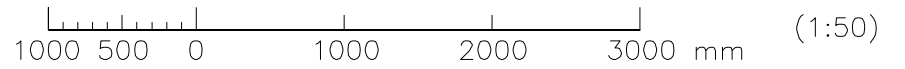

GHD House, 239 Adelaide Terrace, Perth WA 6004 Australia  
 T 61 8 6222 8222 F 61 8 6222 8555  
 E permail@ghd.com.au W www.ghd.com.au

FOR GENERAL NOTES REFER DRG HW91-2-13-1

DES CALC  
E. BISHOP

DES CHD  
G. DUNLOP

DRN  
K. BOSMAN

Q.C. CHD  
R. SPILLANE

RECOMMENDED 06/02/2014  
P.G. SPENCER (SIGNED)

for CONSULTANT JOB MANAGER

APPROVED 06/02/2014  
P.G. SPENCER (SIGNED)

CONSULTANT PROJECT DIRECTOR



METROPOLITAN WASTEWATER WAPC 127155  
 BALANNUP PUMPING STATION NO.175-01 - COLLARED ST & PM  
 DN450 PE PRESSURE MAIN - BUSH FOREVER AREA  
 TYPICAL SECTION OF ECO PLOUGH THROUGH BUSH FOREVER AREA

FILE JT1 201202141 VO1

PROJECT C-S01249

PLAN

HW91-2-13-2

CAD ISSUE

A MF

ORIGINAL SHEET SIZE

A3

283



NOTE:  
THE LOCATION OF OTHER UTILITIES HAS NOT NECESSARILY BEEN ESTABLISHED BY SURVEY, BUT IS BASED ON DIGITAL SERVICE DATA PROVIDED BY THE ASSET OWNERS AND IS INDICATIVE ONLY. SERVICES MUST BE LOCATED AND VERIFIED ON SITE. FOR MORE INFORMATION CONTACT DIAL BEFORE YOU DIG ON 1100 OR WWW.1100.COM.AU

LEGEND

PROPOSED SEWER PRESSURE MAIN	--- PM ---
EXISTING WATER MAINS	--- W ---
EXISTING TELECOMMUNICATION CABLES	--- T ---
EXISTING OPTIC FIBRE	--- OF ---
EXISTING UNDERGROUND POWER	--- UP ---
EXISTING OVERHEAD POWER	--- OP ---
EXISTING GAS MAINS	--- G ---
EXISTING SEWER MAINS	--- S ---
EXISTING SEWER PRESSURE MAINS	--- PH ---
EXISTING DRAINAGE	--- D ---
EXISTING FENCE	--- F ---
EXISTING TREE	(Tree Symbol)
EXISTING BUSHLINE	(Bushline Symbol)
JACKSONIA GRACILLIMA LOCATION	(Location Symbol)

GENERAL NOTES

- PRESSURE MAIN SHALL BE SET OUT AS SHOWN ON THE DRAWINGS WITH REAL TIME RECORDING OF ALIGNMENT GPS CO-ORDINATES, INCLUDING DEPTH, USING IN-VEHICLE ELECTRONIC EQUIPMENT.
- NO DEVIATION FROM THE ALIGNMENT SHOWN IS ACCEPTABLE UNLESS APPROVED IN WRITING BY THE SUPERINTENDENT.
- PRESSURE MAIN SHALL HAVE A MINIMUM DEPTH OF COVER OF 900mm.
- PRESSURE MAIN SHALL BE LAID TO UNIFORM GRADE BETWEEN INVERT LEVELS SHOWN.
- PRIOR TO CONSTRUCTION OF THE PRESSURE MAIN THE EXISTING DRAIN AS SHOWN ON DRAWING HW91-2-15 SHALL BE REMOVED TO 3 METRES EITHER SIDE OF THE TRACK CENTRELINE. THE DRAIN SHALL BE REINSTALLED AT ITS ORIGINAL LEVELS ON COMPLETION OF INSTALLATION OF THE PRESSURE MAIN.
- PE PRESSURE MAIN TO BE AS/NZS4130, SERIES 1. PRESSURE MAIN PIPES TO BE COLOURED BLACK.
- DEFLECTION AT BENDS SHALL BE ACHIEVED BY BENDING THE PIPE IN ACCORDANCE WITH MANUFACTURER'S RECOMMENDATIONS.
- PE PIPES SHALL BE BUTT FUSION WELDED.
- NO CONSTRUCTION OR LAYDOWN AREAS TO BE CREATED WITHIN THE 'BUSH FOREVER' AREA OTHER THAN WITHIN THE APPROVED CLEARED TRACK ALIGNMENT.
- NO CLEARING OR DAMAGE TO BUSHLAND SHALL OCCUR OUTSIDE THE APPROVED CLEARED TRACK ALIGNMENT WITHIN THE 'BUSH FOREVER' AREA.
- JACKSON GRACILLIMA, AS LOCATED ON THE PLANS, ARE NOT TO BE REMOVED OR DAMAGED DURING CONSTRUCTION.
- ANY CONSTRAINTS TO CONSTRUCTION OR DAMAGE TO EXISTING FLORA TO BE REPORTED IMMEDIATELY TO THE SUPERINTENDENT.
- NO DEWATERING OR OPEN TRENCHING (OTHER THAN DRAIN CROSSING INDICATED ON DRG 2-15) TO BE CARRIED OUT WITHIN THE BUSH FOREVER AREA.

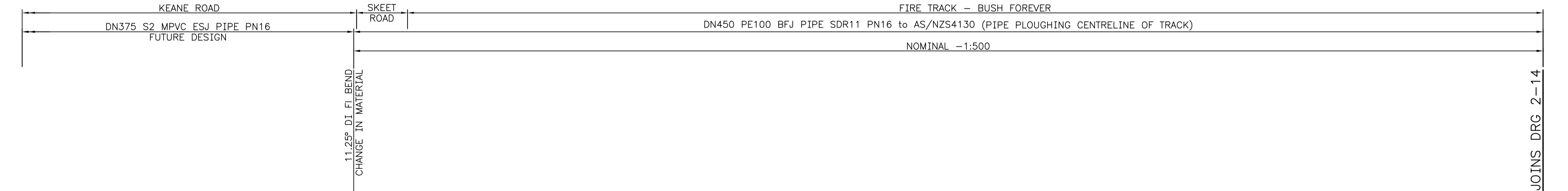
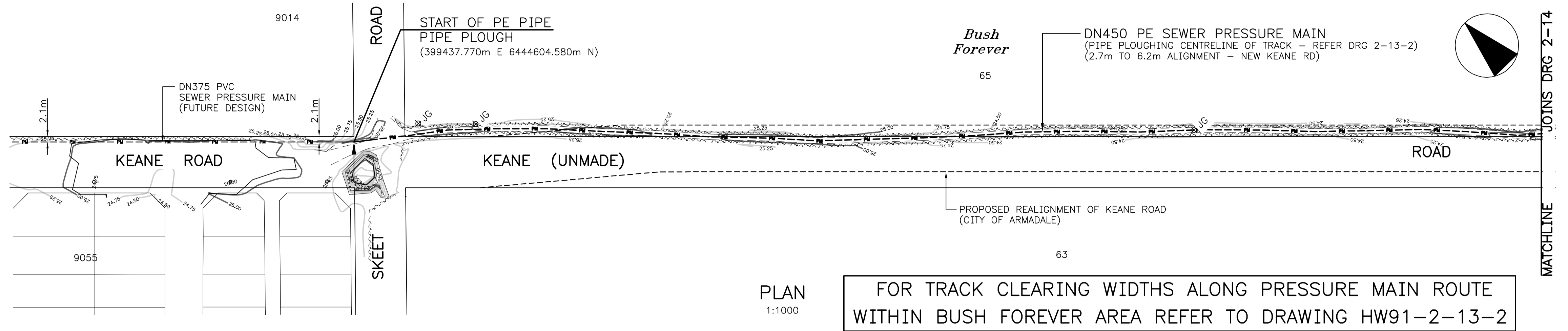

	DATUM 15.00m ABOVE AHD													
EXISTING SURFACE LEVEL	25.00	25.00	25.00	25.00	25.00	25.00	24.75	24.50	24.25	24.25	24.25	24.00	24.00	
DEPTH TO INVERT	1.57								1.35				1.48	
INVERT LEVEL	23.43								22.90				22.47	
HORIZONTAL DISTANCE	0.0	26.0	47.6	82.7	115.9	144.7	199.5	233.5	253.9	303.7	399.4	426.6	448.4	469.2

LONGITUDINAL SECTION  
HORIZONTAL 1:1000, VERTICAL 1:100

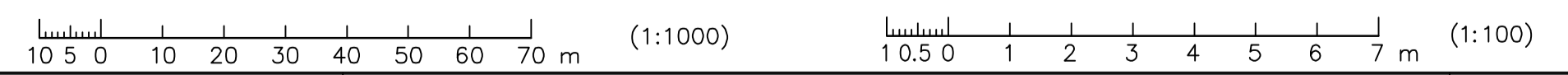

ISSUE	DATE	GRID	REVISION	DRN	REC	APPD
810						

DESIGN SURVEY GHD 2661551 V01	VERTICAL DATUM AHD COORDINATE SYS MGA94-50	DES CALC E. BISHOP DES CHD G. DUNLOP	NORTH POINT
ASCOS SURVEY NONE	DES REF GHD 61-29471	DRN K.BOSMAN Q.C. CHD R.SPILLANE	



RECOMMENDED P.G. SPENCER (SIGNED) for CONSULTANT JOB MANAGER	06/02/2014
APPROVED P.G. SPENCER (SIGNED) CONSULTANT PROJECT DIRECTOR	06/02/2014



METROPOLITAN WASTEWATER WAPC 127155 BALANNUP PUMPING STATION NO.175-01 - COLLARED ST & PM DN450 PE PRESSURE MAIN - BUSH FOREVER AREA PLAN AND LONGITUDINAL SECTION - SHEET 1 OF 3		ORIGINAL SHEET SIZE <b>A1</b>
FILE JT1 201202141 V01	PLAN <b>HW91-2-13-1</b>	CAD ISSUE A MF
PROJECT C-S01249		

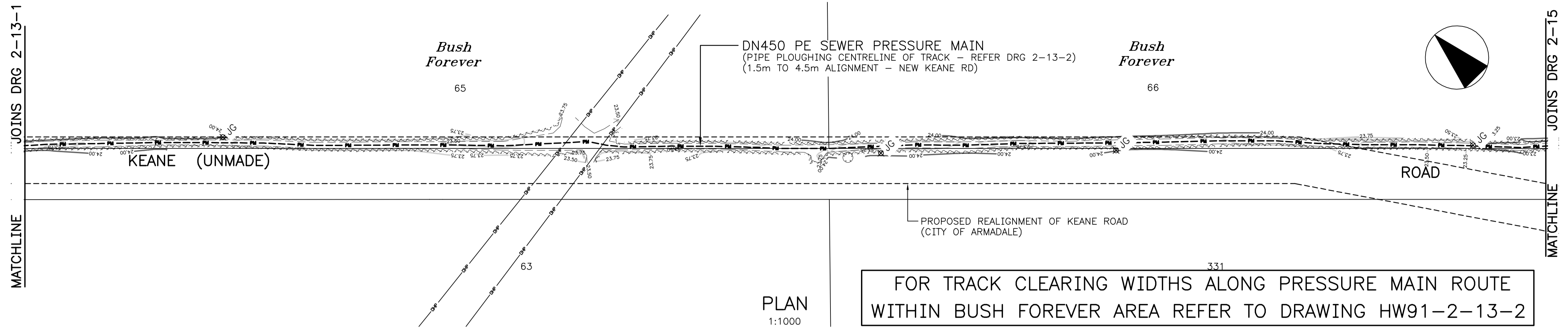

NOTE:  
THE LOCATION OF OTHER UTILITIES HAS NOT NECESSARILY BEEN ESTABLISHED BY SURVEY, BUT IS BASED ON DIGITAL SERVICE DATA PROVIDED BY THE ASSET OWNERS AND IS INDICATIVE ONLY. SERVICES MUST BE LOCATED AND VERIFIED ON SITE. FOR MORE INFORMATION CONTACT DIAL BEFORE YOU DIG ON 1100 OR WWW.1100.COM.AU

LEGEND

PROPOSED SEWER PRESSURE MAIN	
EXISTING WATER MAINS	
EXISTING TELECOMMUNICATION CABLES	
EXISTING OPTIC FIBRE	
EXISTING UNDERGROUND POWER	
EXISTING OVERHEAD POWER	
EXISTING GAS MAINS	
EXISTING SEWER MAINS	
EXISTING SEWER PRESSURE MAINS	
EXISTING DRAINAGE	
EXISTING FENCE	
EXISTING TREE	
EXISTING BUSHLINE	
JACKSONIA GRACILLIMA LOCATION	

FOR GENERAL NOTES REFER DRG HW91-2-13-1

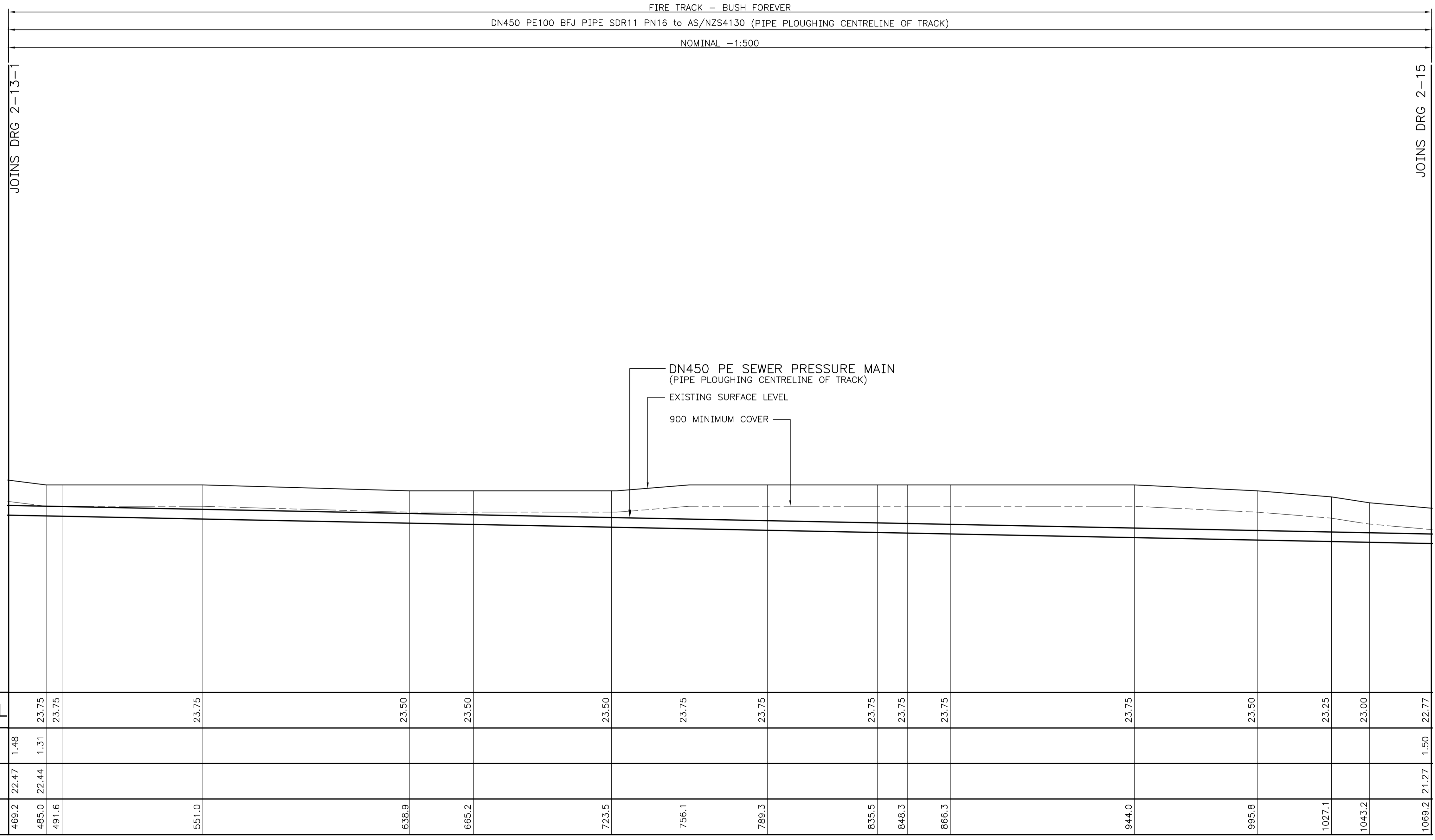

LONGITUDINAL SECTION  
HORIZONTAL 1:1000, VERTICAL 1:100



ISSUE	DATE	GRID	REVISION	DRN	REC	APPD

DESIGN SURVEY GHD 2661551 V01	VERTICAL DATUM AHD COORDINATE SYS MGA94-50	DES CALC E. BISHOP DES CHD G. DUNLOP	NORTH POINT
ASCON SURVEY NONE	DES REF GHD 61-29471	DRN K.BOSMAN Q.C. CHD R.SPILLANE	



GHD House, 239 Adelaide Terrace, Perth WA 6004 Australia  
T 61 8 6222 8222 F 61 8 6222 8555  
E permail@ghd.com.au W www.ghd.com.au

RECOMMENDED P.G. SPENCER (SIGNED)	06/02/2014
for CONSULTANT JOB MANAGER	
APPROVED P.G. SPENCER (SIGNED)	06/02/2014
CONSULTANT PROJECT DIRECTOR	



METROPOLITAN WASTEWATER WAPC 127155 BALANNUP PUMPING STATION NO.175-01 - COLLARED ST & PM DN450 PE PRESSURE MAIN - BUSH FOREVER AREA PLAN AND LONGITUDINAL SECTION - SHEET 2 OF 3		ORIGINAL SHEET SIZE <b>A1</b>
FILE JT1 201202141 V01	PLAN <b>HW91-2-14</b>	CAD ISSUE A MF
PROJECT C-S01249		



NOTE:  
THE LOCATION OF OTHER UTILITIES HAS NOT NECESSARILY BEEN ESTABLISHED BY SURVEY, BUT IS BASED ON DIGITAL SERVICE DATA PROVIDED BY THE ASSET OWNERS AND IS INDICATIVE ONLY. SERVICES MUST BE LOCATED AND VERIFIED ON SITE. FOR MORE INFORMATION CONTACT DIAL BEFORE YOU DIG ON 1100 OR WWW.1100.COM.AU

LEGEND

- PROPOSED SEWER PRESSURE MAIN
- EXISTING WATER MAINS
- EXISTING TELECOMMUNICATION CABLES
- EXISTING OPTIC FIBRE
- EXISTING UNDERGROUND POWER
- EXISTING OVERHEAD POWER
- EXISTING GAS MAINS
- EXISTING SEWER MAINS
- EXISTING SEWER PRESSURE MAINS
- EXISTING DRAINAGE
- EXISTING FENCE
- EXISTING TREE
- EXISTING BUSHLINE
- JACKSONIA GRACILLIMA LOCATION

FOR GENERAL NOTES REFER DRG HW91-2-13-1

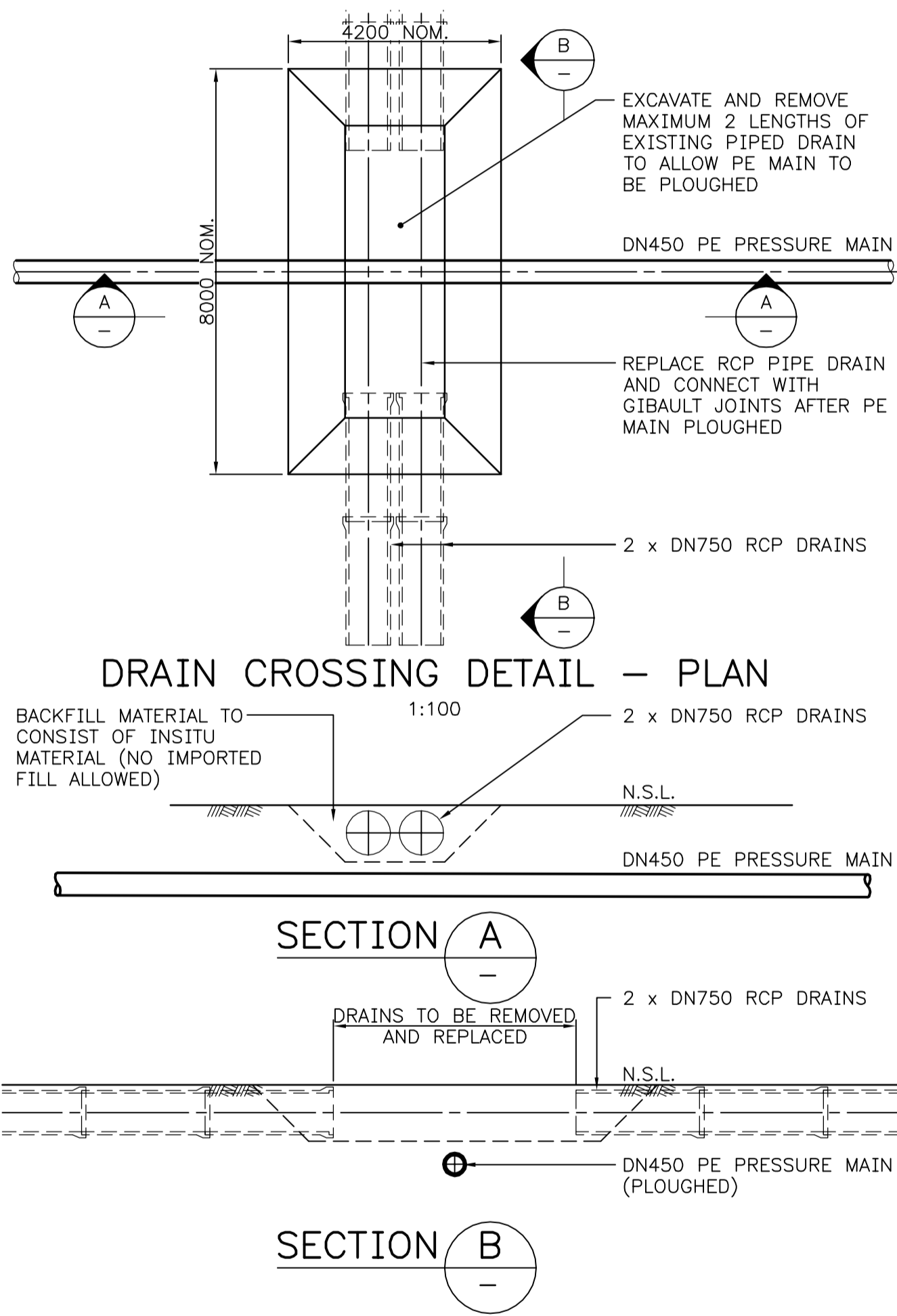

DATUM 15.00m ABOVE AHD

EXISTING SURFACE LEVEL	22.77	22.75	22.50	22.50	22.25	22.25	22.25	22.50	22.77	23.00	23.00	22.75
DEPTH TO INVERT	1.50		1.43						2.39	2.18		1.45
INVERT LEVEL	21.27		21.07						20.38	20.82		21.30
HORIZONTAL DISTANCE	1068.2	1102.2	1171.1	1214.9	1343.5	1450.8	1485.7	1495.2	1502.8	1515.7	1522.8	1541.9

LONGITUDINAL SECTION  
HORIZONTAL 1:1000, VERTICAL 1:100

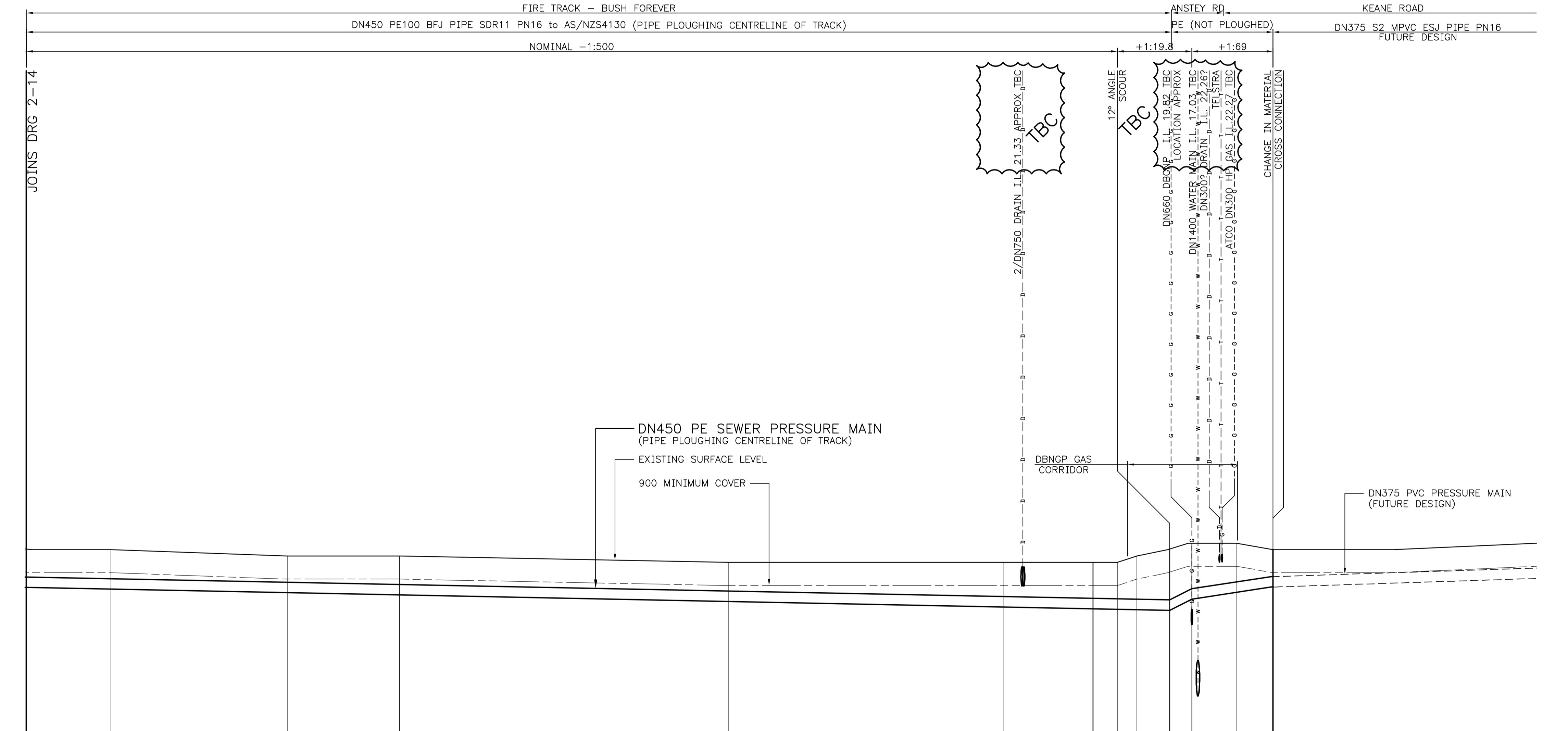
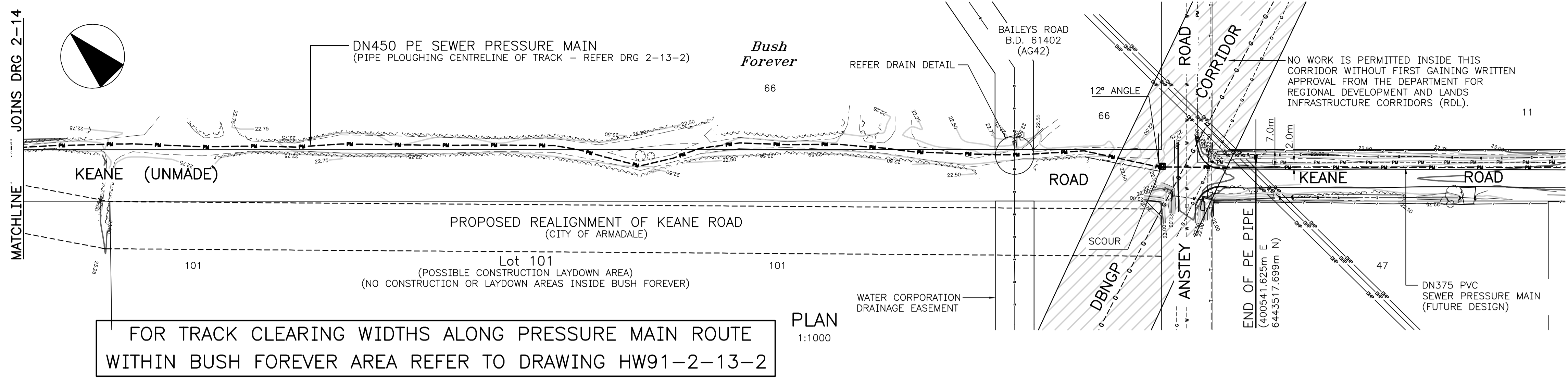

ISSUE	DATE	GRID	REVISION	DRN	REC	APPD
810						

DESIGN SURVEY GHD 2661551 V01	VERTICAL DATUM AHD COORDINATE SYS MGA94-50	DES CALC E. BISHOP DES CHD G. DUNLOP	NORTH POINT
ASCON SURVEY NONE	DES REF GHD 61-29471	DRN K.BOSMAN Q.C. CHD R.SPILLANE	

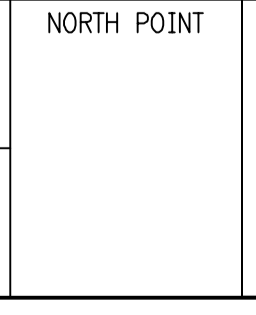

GHD House, 239 Adelaide Terrace, Perth WA 6004 Australia  
T 61 8 6222 8222 F 61 8 6222 8555  
E permail@ghd.com.au W www.ghd.com.au

RECOMMENDED P.G. SPENCER (SIGNED) for CONSULTANT JOB MANAGER	06/02/2014
APPROVED P.G. SPENCER (SIGNED)	06/02/2014
CONSULTANT PROJECT DIRECTOR	



METROPOLITAN WASTEWATER WAPC 127155 BALANNUP PUMPING STATION NO.175-01 - COLLARED ST & PM DN450 PE PRESSURE MAIN - BUSH FOREVER AREA PLAN AND LONGITUDINAL SECTION - SHEET 3 OF 3	FILE JT1 201202141 V01	PLAN	ISSUE A	ORIGINAL SHEET SIZE A1
PROJECT C-S01249	HW91-2-15		MF	



# EcoPlough

## Construction Methodology

**Balannup A Wastewater Sewerage Pump Station and Pressure Main – OD  
450mm PN16 HDPE Pipeline Installation**

**Water Corporation**



# **ECO**PLOUGH

# Contents

<b>1</b>	<b>Purpose</b> .....	<b>3</b>
<b>2</b>	<b>Scope</b> .....	<b>3</b>
<b>3</b>	<b>Definitions</b> .....	<b>3</b>
<b>4</b>	<b>References</b> .....	<b>3</b>
<b>5</b>	<b>Responsibilities</b> .....	<b>4</b>
<b>6</b>	<b>Construction Methodology</b> .....	<b>4</b>
6.1	Summary .....	4
6.2	Preliminaries .....	4
6.3	Site Investigation .....	5
6.4	Protection of Existing Services and Structures .....	5
6.5	Clearing Minimisation .....	5
6.6	Ground Penetration .....	5
6.7	Access/Egress .....	5
6.8	Warning signs .....	6
6.9	Barricading .....	6
6.10	Inspection and Testing .....	6
6.11	Danger Tape & Tracer Wire .....	6
6.12	Quality Control .....	6
<b>7</b>	<b>Ploughing</b> .....	<b>7</b>
7.1	GPS Tracking and Data Collection .....	7
7.2	Entry and Exit Holes .....	7
7.3	Spotters .....	8
7.4	Other plant roles .....	8
7.5	Plough Operation .....	8
<b>8</b>	<b>EcoPlough Trenchless Installation Methodology</b> .....	<b>9</b>
<b>9</b>	<b>Health, Safety &amp; Environmental Management</b> .....	<b>10</b>
9.1	Background .....	10
9.2	Health & Safety Management .....	10
9.3	Environment Management .....	10
9.4	Water Table Validation & Mitigation .....	10
9.5	Hazard Identification, Risk Assessment and Control .....	10
<b>10</b>	<b>Process Maps</b> .....	<b>11</b>
<b>11</b>	<b>Job Safety Analysis (JSA)</b> .....	<b>12</b>
<b>12</b>	<b>Inspection Test Plan (“ITP”)</b> .....	<b>22</b>
	Inspection and Test Plan (ITP) – Ploughing .....	22
<b>13</b>	<b>Site Inspection Photographs</b> .....	<b>26</b>

## 1 Purpose

The purpose of this Construction Methodology is to define the site-specific tasks relating to the construction of the Balannup A Wastewater Pump Station (WWPS) Pressure Main. It details the general requirements, quality requirements, protection to foreign services, safety and environmental issues.

## 2 Scope

This Construction Methodology applies to all employees and sub-contractors in the performance of their duties for Underground Services Australia ("USA") on the construction of the Balannup A WWPS Pressure Main.

## 3 Definitions

**Ploughing** A trenchless service installation method using a heavy blade to create a furrow in which the service package is immediately placed behind the blade before the spoil settles back into the void. Excess spoil is spread within defined parameters and rolled using appropriate machinery.

## 4 References

- GHD Pty Ltd Engineering Summary Report, Balannup Pump Station A (Collared St) M&E Upgrade & New Pressure Main (Keane Rd), Water Corporation Project Number: C-S01249, Revision C
- GHD Pty Ltd Report on the Geotechnical, Acid Sulphate Soils and Contaminated Sites Investigation, Balannup A WWPS and Keane Road Pressure Main, November 2013
- Water Corporation ASSDMP
- Occupational Safety and Health Act 1984
- Occupational Safety and Health Regulations 1996
- Excavation Code of Practice 2005
- Traffic management-Works on Roads Code of Practice 2008
- Restoration and Reinstatement Code of Practice 2002
- Utility providers Code of Practice 2010
- Australian Standard - AS 2885.1 -1997 Part 1. Section 6
- Australian Standard - AS 1270 Acoustics - Hearing protectors
- Australian Standard - AS 1336 Recommended practices for occupational eye protection
- Australian Standard - AS 1337 Eye protectors for industrial applications
- Australian Standard - AS 1800 Occupational protective helmets - Selection, care and use
- Australian Standard - AS 1801 Occupational protective helmets
- Australian Standard - AS 1885.1 Workplace injury and disease recording
- Australian Standard - AS 2161 Occupational protective gloves
- Australian Standard - AS 2210 Occupational protective footwear
- Australian Standard - AS 4360 Risk Management
- Australian Standard - AS 1742.3 Manual of uniform traffic control
- Underground Services' Work Practice Manual – including but not limited to;
  - USA-OPS-WP-04-01 Manual Handling Safety
  - USA-OPS-WP-05-01 Excavation and Trenching
  - USA-OPS-WP-05-03 Locating Services
  - USA-OPS-WP-05-04 Safe Use of Prodders
  - USA-OPS-WP-05-05 Excavation Soil Management
  - USA-OPS-WP-05-06 Barricading
  - USA-OPS-WP-08-02 Butt Fusion Welding
  - USA-OPS-WP-10-01 Ploughing
  - USA-OPS-WP-12-02 Dewatering & Pumping Waste Water
  - USA-OPS-WP-12-04 Site Protection and Restoration of Vegetation
  - USA-OPS-WP-12-09 Fuel and Chemical Spill Control and Clean-Up
  - USA-OPS-WP-12-10 Management of Flora & Fauna
  - USA-OPS-WP-12-11 Erosion & Sediment Control
  - USA-OPS-WP-12-14 Heritage and Archaeology

- Underground Services Environment Management Plan USA-ENV-EMP-001
- Underground Services' Policies and Procedures – including but not limited to;
  - USA-OSH-PRO-013 OSH&E Responsibility & Accountability Procedure
  - USA-OSH-PRO-019 Job Safety Analysis (“JSA”) Procedure
  - USA-POL-004 OHS Policy
  - USA-POL-005 Environmental Policy
- Emergency Response Plan
- Traffic Management Plan (“TMP”)
- Current Dial Before You Dig (“DBYD”) Plans
- Water Corporation Clearance to Work Permit

## 5 Responsibilities

The Project Organisation chart outlines the management structure of the project.

It is the responsibility of the Project Manager/Project Supervisor to ensure the requirements of this Methodology are understood by all employees and that they have the capacity to comply with this procedure. Project Specific inductions will cover the existence and importance of the task specific work practices. The Project Manager will ensure that Safe Work Practices for specific tasks are covered in regular toolbox meetings. All Work Practice requirements will be monitored and compliance audited by the Health, Safety, Environment and Quality (“HSEQ”) Manager. Any non-compliance/issues will be reported to the Project Manager as well as the Water Corporation Site Representative.

The Project Supervisor will delegate day to day duties to the project team.

The roles and responsibilities to carry out the OSH&E functions of this Methodology are defined in the Responsibility and Accountability Procedure.

## 6 Construction Methodology

### 6.1 Summary

The ploughing will allow the pipe line and associated pipework to be installed without undue stresses, free from defects at the time of installation and in accordance with the Water Corporation's Technical Specification or Direction, Alignment Sheets and other relevant standards, drawings and data tables. The installation will provide an environment that will prevent any such defects occurring during its testing and subsequent operating life.

Environmental concerns and landowner issues will be considered and will be addressed prior to the commencement of any works. Similarly, care and protection of existing foreign services will be exercised and conditions of each service provider will be adhered to.

Safety risks (i.e. depth of excavation, ground condition, underground foreign services, proximity to public and other infrastructure, access, etc.) will be assessed and considered prior to works as a part of the JSA process.

### 6.2 Preliminaries

The HSEQ Manager or his nominee will confirm to the supervisor that all personnel involved in the works have attended the Project Induction.

The supervisor will ensure that all safety precautions and recommendations have been implemented, JSA's have been reviewed, discussed and signed on to, and that all personnel involved have the required safety equipment and Personal Protective Equipment (“PPE”). This must include all safety risks (i.e. depth of excavation, ground condition, underground foreign services, proximity to public and other infrastructure, access, etc.) that are highly likely while undertaking the ploughing work.

The specific environmental management actions will be determined and implemented in accordance with the Water Corporation's Construction Environmental Management Framework (CEMF), which will be prepared prior to construction, and all relevant approvals and permits. The CEMF will include site specific requirements regarding dewatering management, lime dosing for ASS management, hygiene (including weed management and dieback) , clearing limitations and all other constraints.

### 6.3 Site Investigation

Investigations ahead of the ploughing will be undertaken to locate and uncover all buried services, underground structures and all other obstructions intersecting or immediately adjacent to the planned pipe location. All such crossings will be clearly marked and exposed (potholed) sufficiently in advance of the works to allow sufficient time to clear the obstruction. Refer to Locating Services Safe Work Practice.

### 6.4 Protection of Existing Services and Structures

This section must be read in conjunction with the Locating Services Safe Work Practice.

USA will obtain contact details for the various authorities responsible for overhead and underground services affected by the work. Prior to commencing work near any such services, USA will notify the relevant authorities of the anticipated schedule of works. Any permit to work that may be issued by the asset owner must be checked prior to excavation and conditions therein must be adhered to.

In the event of damage to a foreign service, the service owner and the Water Corporation's Site Representative will be informed immediately. The service excavation will remain open until the owner has approved the repair, wherever possible without affecting public or employee safety.

### 6.5 Clearing Minimisation

All works will be conducted within the cleared fire access track where practicable, or within a 4 m demarcated construction corridor. Some areas require the plough to track over sections of native vegetation. This work will be carried out without removing original vegetation to enable faster regeneration of the flora once the works have been completed.

All sign boards, post and features will be delicately removed to enable reinstatement without any damage.

### 6.6 Ground Penetration

Before beginning any plough works the Project Supervisor will ensure that all underground services and cabling are located as per the Dial Before You Dig plans and positively identified as appropriate (i.e. gas pipeline, optic fibre, pipeline cathodic protection, earth matting etc.). These services will be protected and marked (pegged or paint) and Clearance to Work requirements implemented prior to plough operations.

All identified services in the vicinity of the works must be isolated or, where isolation is not possible, physically marked and protected against accidental damage.

Minor excavations (1000mm wide by 1500mm deep and 5000mm long) are required in addition to the plough works to allow for entry and exit of the plough blade. Where practicable, the entry and exit points for the plough blade will be excavated outside of the Bush Forever area and will remain within the demarcated construction footprint.

Any mechanical excavation work must be carried out with a dedicated spotter (Safety Observer) in place. All minimum clearances for mechanical excavations set out in USA-OPS-WP-05-01 Excavation and Trenching should be maintained unless otherwise specified by the service owner.

Where the possibility of underground services exists in an area that is to be excavated and there is no information about the existence of these services, then controlled mechanical and manual digging with a permanent spotter (Safety Observer) is to be used or a service location crew is to be brought in to remove any doubt as to the existence of services before normal excavation commences.

### 6.7 Access/Egress

All accessible areas of an excavation of more than 150 mm below grade level whether temporary or permanent must be adequately signposted and/or protected to identify the potential hazard and prevent unauthorised access.

No person will enter any excavation created outside the Bush Forever area until the Project Supervisor has granted permission to enter and has checked and ensured that the excavation or furrow is safe.

Due to the EcoPlough methodology only a shallow furrow will be present. As a result shoring, battering and/or benching will not be required, however for all excavations outside of the Bush Forever site that exceed 1.5m, the applicable legislation will be followed. Safe access and egress will be provided in the form of ladder(s), ramp(s) or stairs; and other personnel will be present at all times that any person is in an excavation.

### 6.8 Warning signs

Where an excavation created outside the Bush Forever area may not be immediately visible to personnel approaching the Site, hazard warning signs will be displayed. This applies to excavations that may be obscured by buildings or equipment.

### 6.9 Barricading

All barricading on site will be erected in accordance with the work practice; USA-OPS-WP-05-06 Barricading.

Materials to be used for barricading will be made available prior to commencing any excavation and erected progressively. Excavated materials may be used to establish a windrow as a barricade. The start and end points of excavations will be barricaded where appropriate. Barricading will be, where practicable, at least 1.5m back from the lip of an excavation.

Barricading must be constructed to a height of not less than 1m and, with the exception of windrow or individual risk assessment in built up areas, barricades positioned no less than 1m from the edge of an excavated area.

### 6.10 Inspection and Testing

The ploughing works will be performed in accordance with the Inspection and Test Plan (ITP) for ploughing. The ITP details the acceptance criteria for each process. It lists the relevant specifications, inspection procedures, test frequency, inspection characteristics and the subsequent verifying records.

ITP details the agreed Hold & Witness Points during the implementation of the works and will be submitted for approval with Water Corporation's Site Representative for approval prior to works commencing on site. The ITP's in Section 12 are samples which, given client approval, will be used for any ploughing works.

### 6.11 Danger Tape & Tracer Wire

Separation distances between danger tape and tracer wire and pipes will be set as per the Water Corporation technical specification.

### 6.12 Quality Control

Inspection holes will be potholed at regular intervals within the first 50m of plough runs. This is to ensure; correct depth of package, correct separation of danger tape and tracer wire and to audit and calibrate the GPS systems

## 7 Ploughing

Ploughing is an efficient, environmentally friendly trenchless underground service installation method. Higher productivity than conventional excavate and lay techniques is possible in suitable ground conditions. Furthermore, the environmental impact of excavations is reduced because there is far less ground disturbance with ploughing and reinstatement occurs soon after service installation.

The EcoPlough is fitted with a GPS Tracking and Data Collection system which collates the GPS Position (Easting & Northing) and depth of the package being installed. The EcoPlough is also fitted with several video cameras as an additional quality assurance measure. The information captured by these cameras is to be reviewed at the completion of the plough run and checked against GPS information. This information is also utilised by the Business Improvement Department to address any issues and to identify areas for improvement.

The requirements of each section are:

### 7.1 GPS Tracking and Data Collection

- The plough supervisor and operator are to be competent in the utilisation / set up of the tracking tool.
- The proposed installation route is to be surveyed by the plough operator and/or surveyor.
  - The existing ground levels are to be stored in the plough's GPS recorder unit alongside the positioning data.
  - File to be saved as a unique specified run.
  - On completion of ploughing the 2 files are overlapped and the depth of the package is collated.
  - All data collated over the life of the project is saved to a Universal Serial Bus ("USB") drive and backed up to the project file as soon as practicable. A copy of the raw data is given to the Client.
  - A diagram can also be produced for the purpose of as-constructed drawings (a surveyor may be required to help complete this task).

### 7.2 Entry and Exit Holes

- Entry and exit holes are required to lower and remove the plough blade.
- Entry and exit holes to be excavated prior to commencement of ploughing.
  - Holes to be 1000mm wide by 1500mm deep by 5000mm long to allow for approximately 1m cover of pipe.
  - Specifications are to be observed and quality control maintained.
- Entry and exit holes shall be excavated and made safe in advance of the plough. This is to eliminate the risk of damage to the package that is being installed.
- Once EcoPlough has moved past the entry/exit hole, the hole is to be made safe by immediately backfilling and compacting wherever practically possible. Safe work distances of personnel will be maintained during excavation activities.
  - All excavation works will be conducted in accordance with USA-OPS-WP-05-01 Excavation and Trenching Work Practice (or as per client specification)
- Chute to be lowered into entry hole
  - Chute to be set to ensure that minimum cover is installed over the service as per design specification. Chains attached to the chute are the guide for depth as a secondary quality check to the plough GPS systems.

### 7.3 Spotters

- Spotters will be used where/if required
- Operator will be using camera system as a primary control

### 7.4 Other plant roles

- Integrated Tool-carrier is to be utilised for the purpose of receiving materials on site and any lifting works that may be required.
- Excavators will be used for excavating entry & exit pits and anchoring the pipe.

### 7.5 Plough Operation

- The plough shall only be operated by a competent and qualified operator.
- Operator is to ensure spotters are aware of intended plough movements by communicating using two-way radio and blasts on the horn. Spotters (where/if required) are to maintain a safe working distance from the plough at all times while it is operating.



## 8 EcoPlough Trenchless Installation Methodology

The process for the installation of a 450OD PN16 HPDE pipe by the EcoPlough is as follows:

**Table 2: EcoPlough Installation Methodology**

Stage	Description
1	Pre-Start meeting with all project personnel prior to any works being undertaken
2	Complete the daily pre-starts for all plant and equipment
3	The Surveyor sets up the base station at the known control point
4	The base station is calibrated and then the surveyor creates the poly line created by establishing the location of the plough line every 50m on straight runs and at every change of direction or deviation from the horizontal alignment of the previous location. The poly line will represent the centre line of the horizontal alignment of the pipe, the accuracy tolerance of this position and the accuracy tolerance of depth will be +/-100mm
5	Test the compaction of the alignment using a standard Penetrometer and record the data for comparison in the final compaction report
6	Pre-rip the horizontal alignment with a D10 Dozer at the full depth of 1500mm for three passes to ensure that the alignment is clear of any objects that could damage the pipe
7	After each individual pass with the D10 they will place the appropriate level of lime in accordance with the Water Corporation ASSDMP using a Front End Wheel Loader with a Stemming Bucket, the Loader will travel up and down the horizontal alignment within the 4m corridor.
8	Unload delivery of pipe and string it out with the Front End Wheeled Loader.
9	Weld the 12m lengths of 450OD PN16 HDPE pipe using the Ritmo Delta 630 All Terrain Fast Fusion Welder along the alignment and within the access track as per USA-OPS-WP-08-02 Butt Fusion Welding.
10	Upon completion of each weld, lift the pipe to one side of the access track using the Front End Wheeled Loader, which will remain in the delineated 4m corridor during the process.
11	Excavate an entry and exit pit with the dimensions 1000x1500x5000 using a 20 tonne Excavator.
12	Attach the chute to the EcoPlough as per the Ploughing Work Practice USA-OPS-WP-10-01.
13	Place the welded pipe to the right hand side of the EcoPlough and secure the pipe into the fair lead roller arrangement.
14	Lower the chute into the entry pit.
15	Feed the welded 450OD PN16 HDPE pipe into the chute into the initial position using the 20 tonne Excavator and soft slings.
16	Secure the end of the rated pulling cone by using a 20 tonne Excavator with an approved lifting eye rated to a safe working load of 10 tonne.
17	Once the end of the pipe is secured and made safe, all personnel will make their way into the safe zone 5m behind the EcoPlough. At no time shall any personnel be allowed to be in front of the EcoPlough until it has come to a complete stop in the exit pit.
18	Commence ploughing at the depth of minimal cover of approximately 1m, the cover will be maintained throughout installation. The pipe will be installed without any undue stress and zero tension,
19	Once the EcoPlough reaches the end of the plough line, hence the chute is now exposed in the exit pit. The EcoPlough is then returned to its standby area.
20	Once the EcoPlough has been moved to the standby area all the GET attachments will be lowered and made safe.
21	The EcoPlough Operator will download all the text data file from the GPS control box inside the EcoPlough and hand it over to the Project Manager, along with video footage of the entire plough route. These will both be used as the final as-constructed drawings.
22	Use a Posi-Track Skid Steer with the Grader Blade attachment to push the furrow into one windrow on top of the plough line.
23	Compact the access track using a 15 tonne Vibe Drum Roller in accordance with client compaction requirements.

## 9 Health, Safety & Environmental Management

### 9.1 Background

Bush Forever Site 342 is recognised as an environmentally sensitive area.

### 9.2 Health & Safety Management

Health & Safety Management is prescribed in the USA-POL-004 OHS Policy and the associated procedures.

### 9.3 Environment Management

Environmental Management is prescribed in the USA-POL-005 Environmental Management Policy and associated procedures. Ploughing and excavation operations will be performed in accordance with Water Corporation's requirements, relevant management plans and approvals.

In the event of a fuel or chemical spill, the spill will be handled and cleaned up as per the Fuel and Chemical Spill Control and Clean-Up Work Practice USA-OPS-WP-12-09.

### 9.4 Water Table Validation & Mitigation

The water level will be determined by potholing to the maximum excavation depth prior to commencement of works.

Works should be undertaken in dry months wherever practicable to avoid any technical dewatering issues that may be encountered based upon information provided in GHD's Report on the Geotechnical, Acid Sulfate Soils and Contaminated Sites Investigation.

In the event that the water table level is above the excavation level, then the excavation does not need to be dewatered as the EcoPlough can successfully function in both wet and dry terrain.

### 9.5 Hazard Identification, Risk Assessment and Control

Ploughing operations will be performed in accordance with Occupational Safety & Health Act 1984, the Workplace Health and Safety Regulations 1996 The Contractor Health & Safety Management Plan, Construction Environmental Management Plan.

Prior to commencing work on site all personnel are required to have satisfactorily completed a site induction held by the HSEQ Representative or appointed delegate. Personnel on site who have not attended the Site Induction will not perform any work and must complete a Visitor's Induction with the Project Supervisor prior to entering site.

10 Process Maps

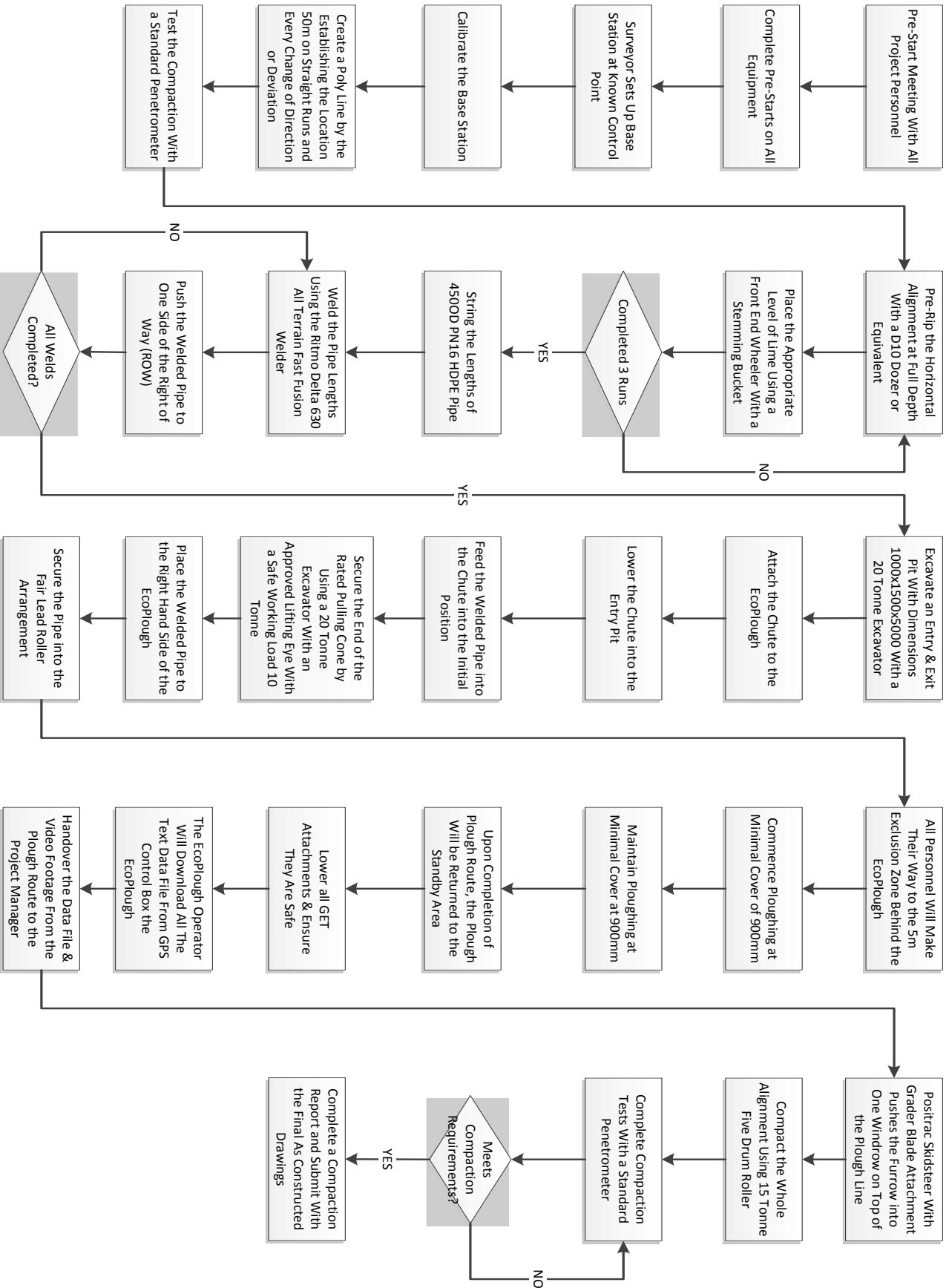

## 11 Job Safety Analysis (JSA)

An example of a typical general works JSA for the Project is included below.

Project: USA Project No:		DATE:	<input checked="" type="checkbox"/> New <input type="checkbox"/> Revised
Project Manager:	Supervisor:	Analysis By:	
Location:	Department:	Reviewed By:	
Personal Protection Equipment: Mandatory: Hi-vis long sleeve and long trousers, safety boots, eye protection, hard hat, wide brims Required when appropriate: Hearing protection, double eye protection		Approved By:	

STEP No.	DESCRIPTION OF JOB/TASKS STEPS What needs to be done step by step?	POTENTIAL INCIDENTS OR HAZARDS What are the potential hazards, situations, or events that can lead to damage or harm?	Consequence, Frequency and RISK LEVEL (Before Controls)			RISK CONTROL MEASURES What controls are in place to reduce the risk level?	RESPONSIBLE PERSONS	Consequence, Frequency and RISK LEVEL (After Controls are in place)		
			F	C	R			F	C	R
1	Mobilisation of plant and equipment to drive on Site	Plant and equipment driving on Site. Traffic injury to personnel / pedestrians. Vehicle/Plant collision	D	2	H	Only project nominated drivers to drive vehicles. All signs to be strictly obeyed at all times. Use Traffic Management Plan as per procedure. All project personnel to wear high-visibility vest / shirt whilst outside a vehicle.	Project Manager Project Supervisors Crew Leader/s Ground personnel	D	3	M

STEP No.	DESCRIPTION OF JOB/TASKS STEPS What needs to be done step by step?	POTENTIAL INCIDENTS OR HAZARDS What are the potential hazards, situations, or events that can lead to damage or harm?	Consequence, Frequency and RISK LEVEL (Before Controls)			RISK CONTROL MEASURES What controls are in place to reduce the risk level?	RESPONSIBLE PERSONS	Consequence, Frequency and RISK LEVEL (After Controls are in place)		
			F	C	R			F	C	R
		Insecure loads accidents caused by vehicle load shift.	D	2	H	When unloading plant, ensure adequate traffic control is organised and utilise traffic controllers when unloading on local roads. Ensure vehicles are not overloaded and that all loads are secure. Decrease speed when transporting heavy loads and increase distance from vehicles in front.	Project Manager Project Supervisors Crew Leader/s Ground personnel	D	3	M
		Oil/fuel spill Damage to Flora/Fauna	D	3	M	Pre-start checks to be conducted on all plant and vehicles daily. Report spills greater than 2 litres. Spills to be treated/recovered using spill kits. No servicing of vehicles on Site. No refuelling within 50m of any water way ESA (Environmentally Sensitive Area)	Project Manager Project Supervisors Crew Leader/s Ground personnel	D	5	L
2	General labouring on Site	Sun Exposure	A	3	E	Apply sunscreen on regular basis. Adequate sun protective clothing/headwear. Maintain adequate drinking water supplies Wear adequate PPE	All Personnel	C	2	H
		Insect Bites	A	5	H	Wear protective clothes. Use insect repellent. Have access to & know how to use tick removal first aid gear.	All Personnel	C	5	L

STEP No.	DESCRIPTION OF JOB/TASKS STEPS What needs to be done step by step?	POTENTIAL INCIDENTS OR HAZARDS What are the potential hazards, situations, or events that can lead to damage or harm?	Consequence, Frequency and RISK LEVEL (Before Controls)			RISK CONTROL MEASURES What controls are in place to reduce the risk level?	RESPONSIBLE PERSONS	Consequence, Frequency and RISK LEVEL (After Controls are in place)		
			F	C	R			F	C	R
		Snake Bites	C	2	H	Be mindful that snakes may be about. Make sure that each crew has snakebite kit handy at all times. Refer Emergency Contact Sheet for contact details regarding removal of snakes.	All Personnel	C	2	H
		Slips/Trips/Falls from Uneven Surfaces	B	4	H	Be constantly aware of the work Site and the fact that uneven surfaces are around, especially when carrying loads. Create a smooth path to & from the required location to minimise the risk of injury. Job checked regularly with regard to temporary repairs prior to final reinstatement. Provide secure access to all work areas, access stairs, ladder, etc.	All Personnel	C	4	L
		Lightning	B	2	E	In event of lightning, cease work and move to area of cover within building or vehicle during period of lightning activity.	All Personnel	B	4	H
		Dust & Sand	A	5	H	Protect eyes with safety glasses (eye protection) when dust and sand is blowing.	All Personnel	A	5	H
		Hazards from working in close proximity to other contractors.	A	4	H	Good communication and consultation required with all working on the Site. Extensive planning required from all to ensure that we are not working on top of other contractors. Ensure when we are working, we have a safe amount of space to conduct our operation.	Project Supervisor Crew Leader Ground Personnel	A	4	H
3	Working in a busy environment	Motor vehicle accident, on work Site Pedestrian/cyclist accident, on the work Site	A	2	E	Ensure traffic/pedestrian management is in place Appropriate signs/barriers/barricades are available on Site or request Fencing /barricading to be appropriate for the work that is being conducted Ensure trenches are backfilled as soon as practicable	Project Supervisor Crew Leader Ground Personnel	C	2	H

STEP No.	DESCRIPTION OF JOB/TASKS STEPS What needs to be done step by step?	POTENTIAL INCIDENTS OR HAZARDS What are the potential hazards, situations, or events that can lead to damage or harm?	Consequence, Frequency and RISK LEVEL (Before Controls)			RISK CONTROL MEASURES What controls are in place to reduce the risk level?	RESPONSIBLE PERSONS	Consequence, Frequency and RISK LEVEL (After Controls are in place)		
			F	C	R			F	C	R
4	Manual Handling	Injuries from incorrect manual handling.	A	4	H	Heavy Lifts – use 2 people or mechanical device. When lifting – Keep loads close to body, keep back straight & bend your knees. Remember to warm up. Avoid twisting when lifting. Be aware of uneven surfaces Follow the CERP for the Project	All Personnel	A	5	H
5	Traffic and Pedestrian Management	Vehicle & Ground Personnel Interaction	A	3	E	Traffic Management to be in place where existing utilities are being located under road pavement. Pedestrian warning signs to be in place where existing utilities are being located under pedestrian ROW's or footpaths.	All Personnel	A	2	E
6	Location of Existing Services	Damage to Services during excavation or injury to personnel	B	2	E	Ensure correct locates for all services are available and on Site in job file. Physically locate all services and complete excavation prior to commencing works as per Services Locating Procedure and Protection of Utilities & Permit to Work.	Locator Project Supervisor Crew Leader	C	2	H
		Injury to Third Party during and after locates being conducted	D	4	L	All excavations to be barricaded as per Barricading Procedure. All temporary repairs to be left in a safe state, locates to be timed to minimise impact on permanent surface treatments, temporary repairs to be monitored and maintained as required.	All Personnel on Site	D	4	L
7	Use of Mechanical Plant on Site	Failure of Mechanical Plant	C	4	M	All new plant to Site to be checked for possible hazards/defects. Plant to have a pre-start inspection daily. All defects to be noted on daily inspection sheet. Any serious defects found, plant to be stood down and workshop notified.	Plant Operators Crew Leader/s Project Supervisor	C	5	L

STEP No.	DESCRIPTION OF JOB/TASKS STEPS What needs to be done step by step?	POTENTIAL INCIDENTS OR HAZARDS What are the potential hazards, situations, or events that can lead to damage or harm?	Consequence, Frequency and RISK LEVEL (Before Controls)			RISK CONTROL MEASURES What controls are in place to reduce the risk level?	RESPONSIBLE PERSONS	Consequence, Frequency and RISK LEVEL (After Controls are in place)		
			F	C	R			F	C	R
		Personnel in close proximity of Plant	A	2	E	Ground personnel to stay appropriate distance outside of swing radius of excavator. Ground Personnel to have and maintain eye contact with operator prior to entering swing radius. Spotters & Plant operators to maintain two way radio contact	Ground Personnel Machine Operators	D	3	M
		Machinery Damaging Existing Below or Above Ground Assets	C	2	H	Located utilities to be confirmed prior to start of excavation; above ground hazards to be identified and appropriate barriers erected to isolate hazard where required.	Ground Personnel Machine Operators Crew Leader	C	3	H
		Trench / Excavation Collapse	C	2	H	Shoring of excavation with sufficiently rated shield, shoring box, timber set where safe battering is impracticable. Spoil to be placed at the required distance from the edge of the excavation, as per Code of Practice, or removal by loader for storage elsewhere on Site. No personnel to enter trench deeper than waist height (1.5m) without shoring or battering to safe angle. Divert surface water using suitable open drain. Pump out groundwater ensuring it does not affect stability of trench walls.	Ground Personnel Machine Operators Crew Leader	D	4	L
		Falling / Slipping / Getting Into/Out of Machinery	D	4	L	Maintain 3 points of contact with the vehicle at all times.	Ground Personnel Machine Operators	D	4	L
8	Exposure to Hazardous materials	Asbestos Interface with Personnel (If Encountered)	C	2	H	Follow Asbestos Handling Procedure	Crew Leader Ground Personnel	C	4	M



STEP No.	DESCRIPTION OF JOB/TASKS STEPS What needs to be done step by step?	POTENTIAL INCIDENTS OR HAZARDS What are the potential hazards, situations, or events that can lead to damage or harm?	Consequence, Frequency and RISK LEVEL (Before Controls)			RISK CONTROL MEASURES What controls are in place to reduce the risk level?	RESPONSIBLE PERSONS	Consequence, Frequency and RISK LEVEL (After Controls are in place)		
			F	C	R			F	C	R
		Materials used in construction	C	2	H	Make available Materials Safety Data Sheet (MSDS) for products used in construction.	Crew Leader Ground Personnel	C	4	M
9	Working in close proximity existing services in open excavations	Machinery too close to edge of trench causing trench sides to collapse	C	3	H	Equipment not to approach closer than top edge of angle of repose, unless shoring box or braced shield in place. No personnel in excavation during placement of backfill by machine.	Machine Operator	C	4	M
10	Backfill and Compaction of Excavations	Back strain or injury lifting compactor into excavation	D	2	H	Use mechanical lifting equipment to lift compactor into trench Use a two person lift if no lifting equipment available.	Machine Operator Ground Personnel	D	4	L
		Confined Space (Breathing problems etc.)	C	2	H	Ensure adequate ventilation Confined Space Risk Assessment Confined Space Accreditation-current	Ground Personnel	C	5	L
		Motor vehicle accident, on the work Site Pedestrian/cyclist accident, on the work Site	C	2	H	Ensure traffic and pedestrian management in place and adhered to. Appropriate signs/barriers/barricades will be in place on the project Site while the works are being carried out. Fencing/ barricading to be appropriate for the work that is being conducted. Ensure trenches are filled as soon as conveniently possible.	Project Manager Project Supervisor Crew Leader	C	4	M
11	Load Shifting by Machine	Injury or death to personnel by falling load	C	2	H	Ticketed operator and qualified dogman required for slinging and lifting of loads. Use of tagged lifting equipment in good condition only.	Operator Dogman Crew Leader	C	4	M
12	Barricading	Unauthorised Personnel entering Site	C	2	H	Install bunting to prevent access to work area and install information tags. Ensure safe entry/exit through/around work site where necessary. Ensure appropriate signs are used. Backfill as appropriate to minimise excavations	Crew Leader Ground Personnel	C	4	M

STEP No.	DESCRIPTION OF JOB/TASKS STEPS What needs to be done step by step?	POTENTIAL INCIDENTS OR HAZARDS What are the potential hazards, situations, or events that can lead to damage or harm?	Consequence, Frequency and RISK LEVEL (Before Controls)			RISK CONTROL MEASURES What controls are in place to reduce the risk level?	RESPONSIBLE PERSONS	Consequence, Frequency and RISK LEVEL (After Controls are in place)		
			F	C	R			F	C	R
						open at any one time. Any hole/open trench must be securely barricaded and barricading checked regularly (must be checked at end of each day) Barricading to be erected as per barricading procedure				
13	Working Under Overhead Power Lines	Electrocution	C	2	H	Ensure that machinery is not within the restricted area OH Power Lines without proper authority. If moving under Power Lines – a spotter is required to ensure the safety distance is maintained according to specifications. Catenaries to be put in place and signposted as required For further information refer to Western Power Work Practise Manual-Section 1/1.8) Any incidents must be reported to the WCWA/regulator	Machine Operators	C	4	M
		Burns	C	2	H	Keep a fire extinguisher/fire blankets handy at all times.	Crew Leader Ground Personnel	C	4	M
		Fire	C	2	H	Ensure surrounding area is free of materials and vegetation where applicable Fire extinguishers/fire blankets to be kept nearby at all times. Follow procedures outlined in CSC	Crew Leader Ground Personnel	C	4	M
14	Hot Work	Fire	C	2	H	Fire extinguishers/fire blankets to be kept nearby at all times. Use a hot work permit	Crew Leader Ground Personnel	C	4	M
15	Locating Underground services	Personal injury from hammering and handling pegs including splinters and/finger crush	C	3	H	Ensure gloves are available to survey crews for handling stakes, pegs and star pickets. Disposable splinter probes to be included in First Aid kits. Do not use broken or damaged stakes, pegs or pickets. Ensure hammer used is suitable for the application. Safety glasses to be worn at all times.	Surveyor Crew Leaders	C	4	M

STEP No.	DESCRIPTION OF JOB/TASKS STEPS What needs to be done step by step?	POTENTIAL INCIDENTS OR HAZARDS What are the potential hazards, situations, or events that can lead to damage or harm?	Consequence, Frequency and RISK LEVEL (Before Controls)			RISK CONTROL MEASURES What controls are in place to reduce the risk level?	RESPONSIBLE PERSONS	Consequence, Frequency and RISK LEVEL (After Controls are in place)		
			F	C	R			F	C	R
		Remote Locating Crew becomes stuck or lost in remote area				Personnel not to work or drive through remote areas alone. Check water depth before driving through creek crossings. Maintain communications and ensure all vehicles carry load rated towrope and adequate drinking water.				
16	Survey Works	Use of Class 1 laser equipment (Survey and general works)	C	4	M	Laser warning signs clearly posted No direct eye contact with laser beam For further information on controls refer to AS 22 11 & AS 2397 (Laser safety AS's)	All Personnel on Site	C	4	M
		Contact with sharp object Lacerations/cuts (Placing stakes and pegs as required)	C	4	M	Wear appropriate PPE in accordance with the JSA established for the task First Aid kits available on Site Qualified SNR First Aiders available on Site (USA)	All Personnel on Site	C	4	M
17	Potholing near electric fence	Contact with electric fence will cause electric shock	C	2	H	Keep clear distance between personnel and electric fence If possible turn electric fence off while working in the area Report any electric shock incidents Electric shocks must be reported to the regulator- Electric sources must be turned off	All Personnel on Site	C	4	M
18	Night Works	Workers fatigue issues	C	2	H	Refer to Safety procedure	All Personnel on Site	C	4	M
		Reduced visibility issues	C	4	M	Portable Light Towers available on Site Traffic Management	Project Supervisor Crew Leader	C	4	M

STEP No.	DESCRIPTION OF JOB/TASKS STEPS What needs to be done step by step?	POTENTIAL INCIDENTS OR HAZARDS What are the potential hazards, situations, or events that can lead to damage or harm?	Consequence, Frequency and RISK LEVEL (Before Controls)			RISK CONTROL MEASURES What controls are in place to reduce the risk level?	RESPONSIBLE PERSONS	Consequence, Frequency and RISK LEVEL (After Controls are in place)		
			F	C	R			F	C	R
		Traffic and Pedestrian management	C	2	H	Signs and cones in place High visibility clothing Traffic controllers in Place as per TM Plan	Project Supervisor Crew Leader	C	4	M
19	Housekeeping	Injury to personnel due to bad housekeeping-trips and slips(rubbish/equipment/tools left lying around) Rubbish not adequately stored increasing risk of combustion	C	4	M	Designated rubbish areas/rubbish bins on Site	All Personnel	C	4	M

**RISK MATRIX**

FREQUENCY	CONSEQUENCE				
	1 Major	2 Significant	3 Moderate	4 Minor	5 Insignificant
A Frequent	Extreme	Extreme	Extreme	High	High
B Often	Extreme	Extreme	High	High	Medium
C Sometimes	Extreme	High	High	Medium	Low
D Rarely	High	High	Medium	Low	Low
E Unlikely	High	Medium	Medium	Low	Low

RISK LEVEL	RESPONSIBILITY / ACTION REQUIRED
Extreme	Unacceptable level of risk. Interim corrective action required to reduce risk immediately, with permanent corrective action planned with high priority.
High	Undesirable level of risk. Interim corrective action required if practicable, with permanent corrective action required to reduce risk with high to medium priority.
Medium	Marginal level of risk. Planned corrective action may be required to reduce risk to lower level if so far as is practicable with medium priority. Alternatively risk may be tolerable and additional corrective action may not be required.
Low	Tolerable level of risk. Risk controlled to 'as low as reasonably practicable' and additional corrective action is not required.

## 12 Inspection Test Plan (“ITP”)

Typical ITP for Ploughing works;

### Inspection and Test Plan (ITP) – Ploughing

Project Name: Underground Services Australia - Project No: Contract No:  
 Client: Contractor: Underground Services Australia Project Location:  
 Description of Item/Service: Plough works ITP No: 3 Rev. 0  
 Works Location: ..... Construction Drawing Number: .....

LEGEND	
H – Hold Point	- work shall not proceed past the Hold Point until released by the organisation imposing the Hold Point.
W – Witness Point	- an inspection point that may be witnessed by the organisation imposing the Witness Point.
I – Inspection	- formal inspection activity to be undertaken and recorded.
S – Surveillance	- an activity that is subject to ongoing monitoring.
R – Review	- review of text reports/records or other evidence of compliance.
RI – Responsible Inspectorate	
Project Supervisor (“PS”)	
Project Engineer (“PE”)	
Project Manager (“PM”)	

REFERENCE DOCUMENTS
Construction Scope of Works
Technical Specifications for Cable Installation
Environmental Management Plan (EMP)
Safety Management Plan (SMP)
Project Execution Plan (PEP)
Daily Job Safety Analysis (JSA)

APPROVAL/REVISION				
Rev	Date	Details	App’d	App’d (Client)
0	07/05/2014	Internal Review	David Lill	

LEGEND SUMMARY									
H – Hold Point	W – Witness Point	I – Inspection	S – Surveillance	R – Review	RI – Responsible Inspector	PS - Project Supervisor	PE - Project Engineer	PM – Project Manager	

Task No.	Task Description	RI	Acceptance Criteria	Applicable Standard (Procedure or Instruction)	Inspection Test		Verification Activity by			Verifying Documents	Verifying Signature
					Method	Frequency	Sub Con	USA	Client		
1.0	Permit to Work	PS or PE	Permit to work application form filled, approved by the client and available on site	PEP EMP, SMP	Review	Prior to Start of Work	H	H	R	Approved Permit to Work	
2.0	Application design change (if applicable)	PS or PE	Proposed change of trench submitted to client and approved	PEP EMP, SMP	Review	Each Change of Design	H	H	R	Approved Variation to Contract	
<b>HOLD POINT</b>							<b>Signed:</b>				
3.0	Check for correct Traffic Management bunting, barricading and signage	PS or PE	Correct bunting, barricading and signage	PEP EMP, SMP	Visual	Prior to Plough	S	S	S	Project File	
4.0	Check ploughing along the proposed line	PS or PE	Plough centreline as per survey layout Material as per construction specification	PEP EMP, SMP	Visual	Each Line	S	I	I	Project File	
5.0	Check Entry / Exit holes excavated in correct location	PS or PE	Correct distance for continuous pipe as per the construction specifications	PEP EMP, SMP	Visual	Each Line	S	S	S	Project File	

Task No.	Task Description	RI	Acceptance Criteria	Applicable Standard (Procedure or Instruction)	Inspection Test		Verification Activity by			Verifying Documents	Verifying Signature
					Method	Frequency	Sub Con	USA	Client		
7.0	Existing underground services	PS or PE	All 3 <sup>rd</sup> party service owners have approved permit to works and been notified prior excavation commencement No services are across the line of the plough or able to be damaged by ploughing works.	PEP EMP, SMP	Visual	Prior to Ploughing	H	H	I	Project File Records	
<b>HOLD POINT</b>							Signed:				
8.0	Installation of pipe and marking devices (danger tape / tracer wire)	PS or PE	Pipe and marking devices installed to the correct depth and with the correct separation	PEP EMP, SMP	Visual	Each Line	H	H	I	Project File Records	
9.0	Reinstatement of plough line and exit / entry holes	PS or PE	Whatever minor ground disturbance that may have been caused is backfilled and reinstated	PEP EMP, SMP	Visual	After ploughing works	S	R	S	Project File	
10.0	Installation of above ground marker devices	PS or PE	As per construction specification	PEP EMP, SMP	Visual	Prior to De-Mobilisation	S	R	S	Project File	



Task No.	Task Description	RI	Acceptance Criteria	Applicable Standard (Procedure or Instruction)	Inspection Test		Verification Activity by			Verifying Documents	Verifying Signature
					Method	Frequency	Sub Con	USA	Client		
11.	Traffic Management and signage removed	PS, PM or PE	All additional material, signs, traffic management devices removed from site	PEP, SMP, EMP	Visual	Prior to De-Mobilisation	S	R	W	Project File Records	
HOLD POINT							Signed:				

### 13 Site Inspection Photographs

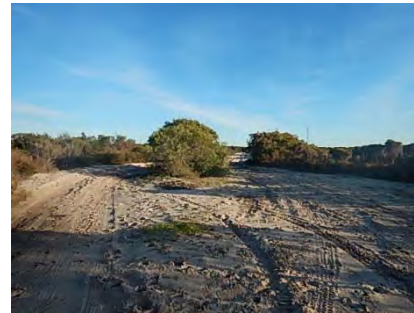

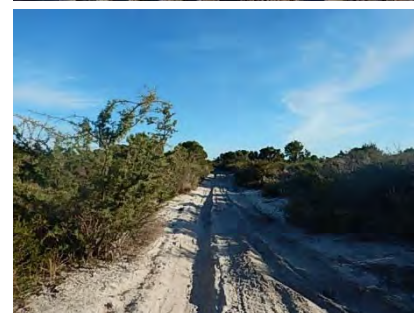
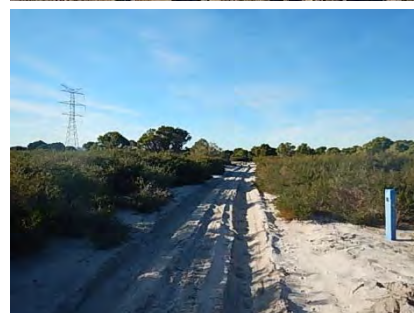
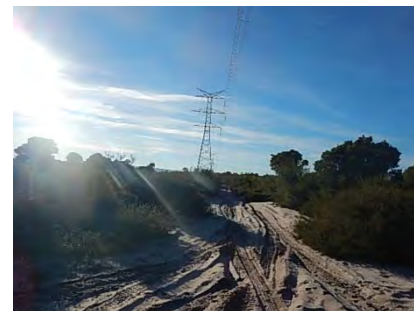
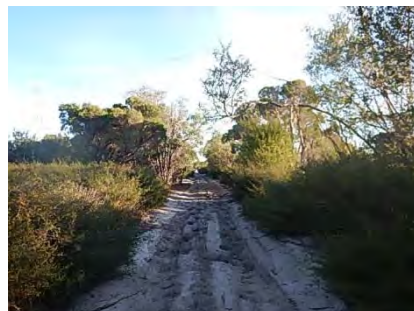

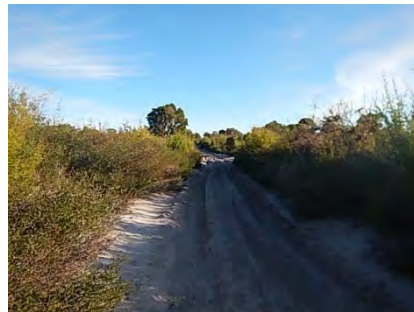

## Appendix C

# Route Options Considered

This page has been left blank intentionally.

**PRELIMINARY ONLY**  
NOT TO BE USED FOR CONSTRUCTION

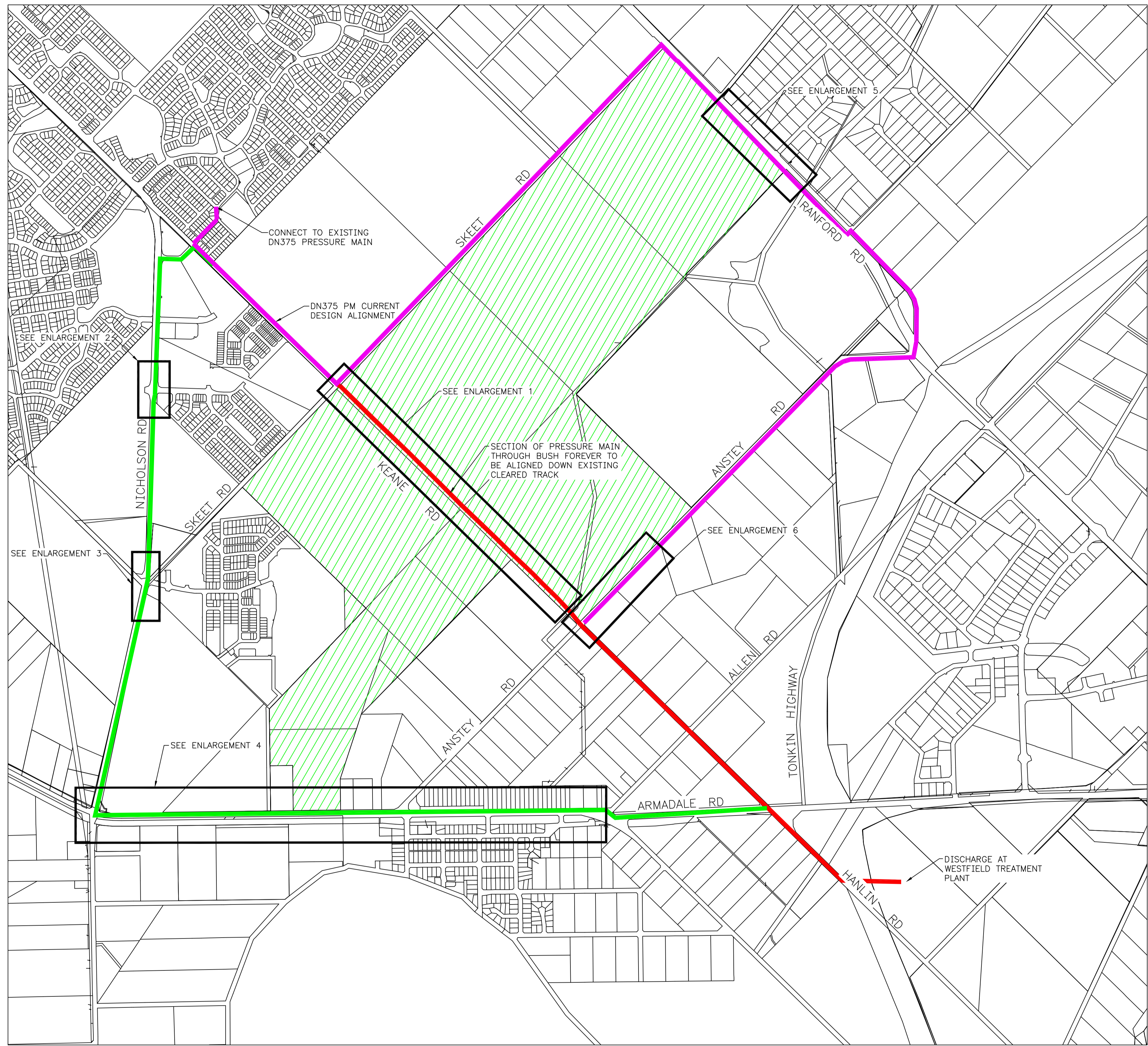

- LEGEND**
- DN375 PM ALIGNMENT OPTION 1
  - DN375 PM ALIGNMENT OPTION 2
  - DN375 PM ALIGNMENT OPTION 3
  - BUSH FOREVER

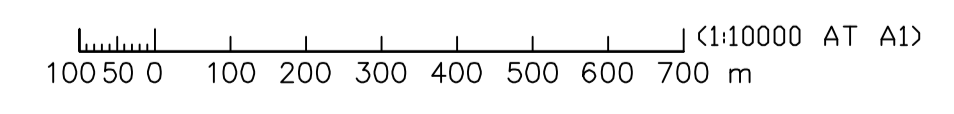

566	ISSUE	DATE	GRID	REVISION	DRN	REC	APPD
810							

DESIGN SURVEY NONE	VERTICAL DATUM NONE	DES CALC DES CHD	NORTH POINT 
ASCON SURVEY NONE	COORDINATE SYS NONE	DES REF DRN	
		Q.C. CHD	

**INFRASTRUCTURE DESIGN BRANCH**

RECOMMENDED  
CONSULTANT PROJECT MANAGER  
APPROVED  
CONSULTANT PROJECT DIRECTOR



METROPOLITAN WASTEWATER BALLANUP PUMPING STATION NO. 175-01 DN375 PRESSURE MAIN ROUTE ALIGNMENT		FILE	PLAN	CAD	ISSUE
		PROJECT C-S01249	HW91	B	MF

ORIGINAL SHEET SIZE  
**A1**







PLAN  
ENLARGEMENT 4  
SCALE (1)



PLAN  
ENLARGEMENT 3  
SCALE (2)



PLAN  
ENLARGEMENT 2  
SCALE (2)

- PROPOSED ALIGNMENT
- EXISTING WASTEWATER
- EXISTING WATER
- EXISTING GAS
- OVERHEAD POWER LINES

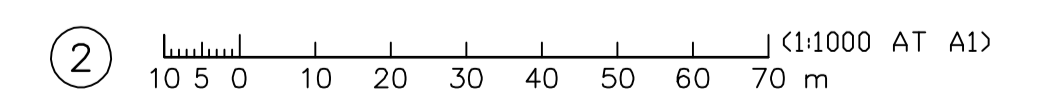
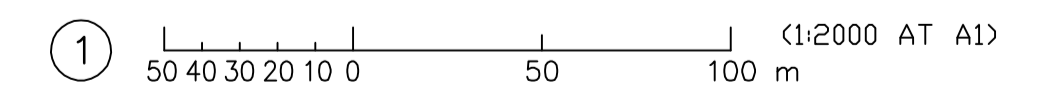

**PRELIMINARY ONLY**  
NOT TO BE USED FOR CONSTRUCTION

ISSUE	DATE	GRID	REVISION	DRN	REC	APPD
566						
810						

DESIGN SURVEY NONE	VERTICAL DATUM	DES CALC	NORTH POINT 
ASCON SURVEY NONE	COORDINATE SYS	DES CHD	
	DES REF	DRN	
		Q.C. CHD	

**INFRASTRUCTURE  
DESIGN  
BRANCH**

RECOMMENDED  
CONSULTANT PROJECT MANAGER  
APPROVED  
CONSULTANT PROJECT DIRECTOR



OPTION 2 CONGESTED AREAS – ENLARGEMENT				ORIGINAL SHEET SIZE
FILE	PLAN	CAD	ISSUE	A1
PROJECT	SHEET 2		MF	

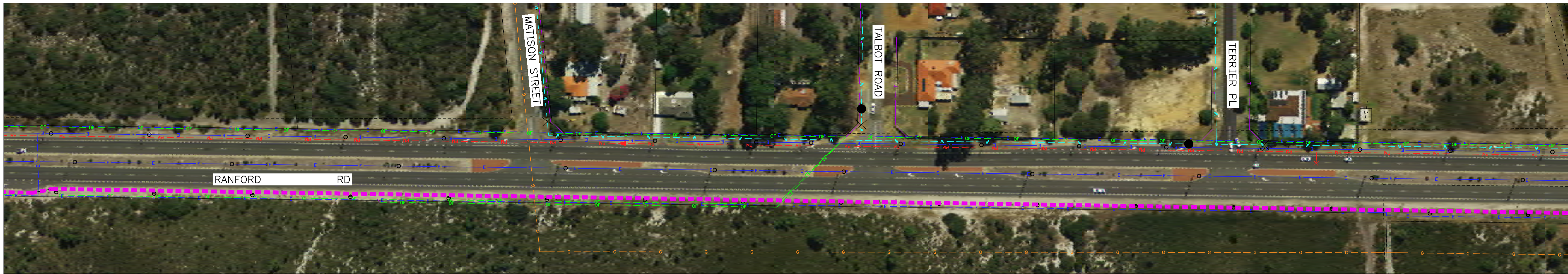











 **RANFORD ROAD**  
ENLARGEMENT 5



 **ANSTEY ROAD**  
ENLARGEMENT 6

**LEGEND**

-  PROPOSED MAIN
-  EXISTING WATER MAIN  
(ALSO HYDRANT, INSP. M/H, VALVE  
CHANGE IN PIPE MATERIAL OR SIZE & AIR RELEASE SHOWN)
-  WASTEWATER PRESSURE MAIN  
(ALSO SCOUR & AIR RELEASE SHOWN)
-  DRAINAGE MAIN
-  GAS MAIN - ?UTILITY
-  OVERHEAD ELECTRICAL CABLES - ?UTILITY  
(ALSO POWER AND LIGHT POLES SHOWN)
-  UNDERGROUND ELECTRICAL CABLES - ?UTILITY
-  TELECOMMUNICATION CABLES - ?UTILITY
-  TELECOMMUNICATION OPTIC FIBRE CABLES - ?UTILITY
-  STREET LIGHT
-  POWER POLE

**GENERAL NOTES:**

1. THE FOLLOWING HAVE NOT BEEN INVESTIGATED:
  - 1.1 LOCAL AUTHORITY STORMWATER MAINS
  - 1.2 EXISTING AND FUTURE SEALED ROADS
  - 1.3 EXISTING SURFACE FEATURES
2. SERVICES SHOWN ON THIS DRAWING:
  - 2.1 THE LOCATIONS HAVE NOT BEEN ESTABLISHED BY SURVEY BUT RATHER BASED ON GENERAL INFORMATION (DBYD) AS AT JUNE 2013.
  - 2.2 SERVICES TO PROPERTIES AND ASSETS MAY BE PRESENT BUT NOT SHOWN (SUCH AS: WATER, ELECTRICITY, GAS, TELECOMMUNICATION, SIGNAL CABLES)
  - 2.3 LANDSCAPING RETICULATION MAY BE PRESENT BUT NOT SHOWN.

Scale bar: 10 5 0 10 20 30 40 50 60 70 mm (1:1 AT A1)

**PRELIMINARY ONLY**  
NOT TO BE USED FOR CONSTRUCTION



DESIGN SURVEY NONE		VERTICAL DATUM		DES CALC		NORTH POINT		<b>INFRASTRUCTURE DESIGN BRANCH</b>	RECOMMENDED			OPTION 3 CONGESTED AREAS - ENLARGEMENT		ORIGINAL SHEET SIZE <b>A1</b>	
		COORDINATE SYS		DES CHD					CONSULTANT PROJECT MANAGER			FILE			SHEET 3
ASCON SURVEY NONE		DES REF		DRN					APPROVED			PLAN			
ISSUE	DATE	GRID	REVISION	DRN	REC	APPD	Q.C. CHD		CONSULTANT PROJECT DIRECTOR				1	MF	

This page has been left blank intentionally.

Appendix D

# Flora, Vegetation and Fauna Report (ENV 2013)

This page has been left blank intentionally.